

GENERAC[®]

MAGNUM

Owner's Manual

For
Diesel Generator
MMG625VT2

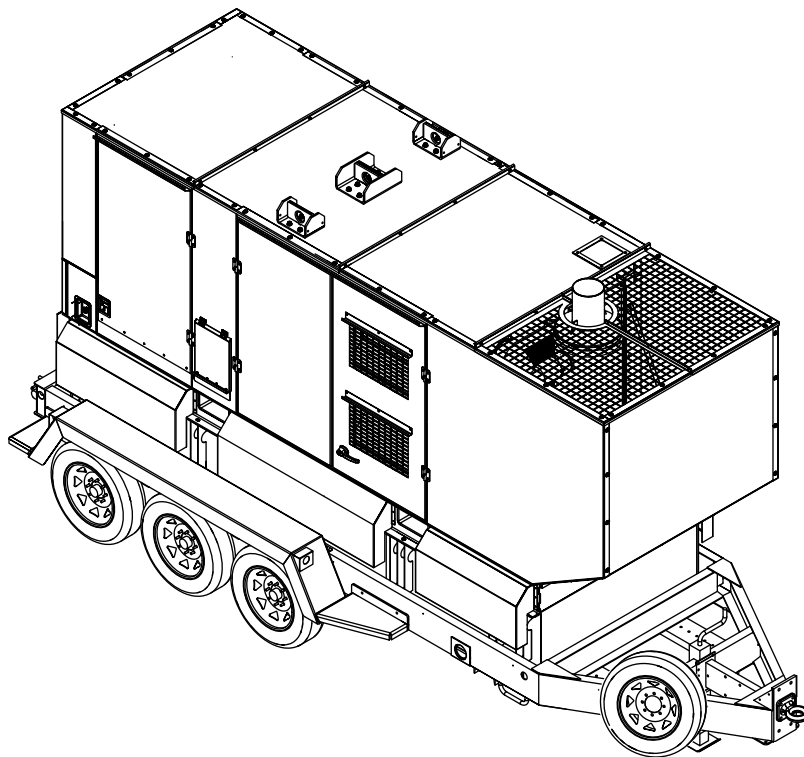

For technical assistance contact:
www.generacmobileproducts.com
Technical Support
1-800-926-9768

SAVE THIS MANUAL FOR FUTURE REFERENCE

Use this page to record important information about your Mobile Generator

Unit Model Number	
Unit Serial Number	
Engine Model Number	
Engine Serial Number	
Generator Model Number	
Generator Serial Number	
Date Purchased	

Record the information found on your unit data label on this page. See unit serial number location ([Unit and Serial Number Locations](#)).

Engine and generator serial numbers are located on separate data plates affixed to the engine and generator respectively.

When contacting a Generac Mobile Products Authorized Dealer about parts and service, always supply the complete model number and serial number of the unit.

Operation and Maintenance: Proper maintenance and care of the generator ensures a minimum number of problems and keeps operating expenses at a minimum. It is the operator's responsibility to perform all safety checks, to verify that all maintenance for safe operation is performed promptly, and to have the equipment checked periodically by a Generac Mobile Products Authorized Dealer. Normal maintenance, service and replacement of parts are the responsibility of the owner/operator and, as such, are not considered defects in materials or workmanship within the terms of the warranty. Individual operating habits and usage may contribute to the need for additional maintenance or service.

⚠ WARNING

California Proposition 65. Engine exhaust and some of its constituents are known to the state of California to cause cancer, birth defects, and other reproductive harm. (000004)

⚠ WARNING

California Proposition 65. This product contains or emits chemicals known to the state of California to cause cancer, birth defects, and other reproductive harm. (000005)

Table of Contents

Introduction and Safety

Introduction	1
Read This Manual Thoroughly	1
Safety Rules	1
General Hazards	2
Explosion and Fire Hazards	2
Trailer Hazards	3
Electrical Hazards	3
Battery Hazards	4

General Information

Component Locations	5
Unit and Serial Number Locations	6
Engine Oil Recommendations	6
Coolant Recommendation	6
Control Panel	7
PowerZone® Controller	8
Controller Features and Functions	9
Home Button	9
Close Generator Circuit Breaker (GCB) Button	9
Open Generator Circuit Breaker (GCB) Button	9
Alarm Mute Button	9
AUTO and MANUAL Mode Buttons	9
Navigation Buttons	9
Control Power Switch	9
Engine Start Button	9
Engine STOP/RESET Button	9
Liquid Crystal Display (LCD)	9
Maintenance Screens	9
Generator Summary	10
Home Tab	10
Engine Tab	10
Generator Tab	10
Bus Tab	11
Alarms Tab	11
Input/Output Tab	12
PLC Tab	12
Schedule Tab	12
Status Tab	12
Controller Information Displays, Functions, and Reset	12
Belt Tensioner	12
Optional Equipment	13
Shorting (Link) Board Option	13

Operation

Prestart Checklist	15
Manually Starting the Unit	15
AUTO (Remote) Starting the Unit	16
Parallel Setup and Operation	16
Ladder Operation	17
Door Latch Operation	17
Viscous Fan Clutch	18
Wet Stacking	18
Engine Derating	18
Cold Starting Operation	18
Generator Output Connections	19
Generator Cam Lock Connections	19
Voltage Regulator	20
Customer Convenience Receptacles	20
Main Circuit Breaker	21
Transfer Switch	21
AUTO Exercise Timer	22
Accessing the Configuration Menu	22
Set the Controller Clock	22
Set the Schedule	22
Setting Up a Daily Scheduled Run	23
Set the Unit to AUTO Mode	23
Shutting Down the Unit	23
Emergency Stop Switch	23
Towing the Unit	23
Lifting the Unit	24

Maintenance

Emissions Information	25
Daily Walk Around Inspection	25
General Maintenance	25
Basic Maintenance Schedule	25
Special Service Intervals	26
Engine Break-In Requirements	26
Resetting the Maintenance Alarms	27
Checking Generator Drive Plate Torque	27
Jack Maintenance	27
Side-Wind Models	27
Top-Wind Models	27
Trailer Wheel Bearings	28

Troubleshooting

General Troubleshooting	29
-------------------------------	----

Wiring Diagrams and Service Log

AC Wiring	31
AC Wiring - Control Panel Receptacles	32
AC Wiring - Link Board Option	33
DC Wiring	34
Engine and Power Wiring (1 of 2)	35
Engine and Power Wiring (2 of 2)	36
DC Wiring - Battery Charger	37
DC Wiring - Engine Heater	38
DC Wiring - Remote Communication (Optional)	39
Trailer Lights	40
Wiring Harness - Electric Brake	41
Paralleling - Plug Resistor	42
Paralleling - Cable Assembly	43
Service Log	44

Section 1 Introduction and Safety

Introduction

Thank you for purchasing a Generac Mobile Products LLC product. This unit has been designed to provide high-performance, efficient operation, and years of use when maintained properly.

The information in this manual is accurate based on products produced at the time of publication. The manufacturer reserves the right to make technical updates, corrections, and product revisions at any time without notice.

Read This Manual Thoroughly



WARNING

Consult Manual. Read and understand manual completely before using product. Failure to completely understand manual and product could result in death or serious injury. (000100a)

If any section of the manual is not understood, contact your nearest Generac Mobile Products Authorized Dealer, or contact Generac Mobile Products (GMP) Customer Service at 1-800-926-9768, or www.generacmobileproducts.com with any questions or concerns.

The owner is responsible for proper maintenance and safe use of the equipment. Before installing, operating, or servicing this generator:

Save these instructions for future reference. This manual contains important instructions for the generator that should be followed during installation, operation and maintenance of the generator and batteries. ALWAYS supply this manual to any individual that will use this machine.

Safety Rules

The manufacturer cannot anticipate every possible circumstance that might involve a hazard. The warnings in this manual, and on tags and decals affixed to the unit are, therefore, not all inclusive. If using a procedure, work method or operating technique that the manufacturer does not specifically recommend, verify that it is safe for others. Also make sure the procedure, work method or operating technique utilized does not render the equipment unsafe.

Throughout this publication, and on tags and decals affixed to the unit, DANGER, WARNING, CAUTION and NOTE blocks are used to alert personnel to special instructions about a particular operation that may be hazardous if performed incorrectly or carelessly. Observe them carefully. Their definitions are as follows:

DANGER

Indicates a hazardous situation which, if not avoided, will result in death or serious injury.

(000001)

WARNING

Indicates a hazardous situation which, if not avoided, could result in death or serious injury.

(000002)

CAUTION

Indicates a hazardous situation which, if not avoided, could result in minor or moderate injury.

(000003)

NOTE: Notes contain additional information important to a procedure and will be found within the regular text of this manual.

These safety warnings cannot eliminate the hazards that they indicate. Common sense and strict compliance with the special instructions while performing the action or service are essential to preventing accidents.

General Hazards



⚠ DANGER

Asphyxiation. Running engines produce carbon monoxide, a colorless, odorless, poisonous gas. Carbon monoxide, if not avoided, will result in death or serious injury. (000103)



⚠ WARNING

Hearing Loss. Hearing protection is recommended when using this machine. Failure to wear hearing protection could result in permanent hearing loss. (000107)



⚠ WARNING

Moving Parts. Keep clothing, hair, and appendages away from moving parts. Failure to do so could result in death or serious injury. (000111)



⚠ WARNING

Hot Surfaces. When operating machine, do not touch hot surfaces. Keep machine away from combustibles during use. Hot surfaces could result in severe burns or fire. (000108)

⚠ WARNING

In case of an emergency, press the emergency stop button to stop the engine immediately. Failure to do so could result in death or serious injury. (000298)

⚠ WARNING

Equipment damage. Do not attempt to start or operate a unit in need of repair or scheduled maintenance. Doing so could result in serious injury, death, or equipment failure or damage. (000291)

⚠ WARNING

Risk of injury. Do not operate or service this machine if not fully alert. Fatigue can impair the ability to service this equipment and could result in death or serious injury. (000215)

⚠ WARNING

Only qualified service personnel may install, operate and maintain this equipment. Failure to follow proper installation requirements could result in death, serious injury, and damage to equipment or property. (000182)

⚠ CAUTION

Equipment or property damage. Do not block air intake or restrict proper air flow. Doing so could result in unsafe operation or damage to unit. (000229)

Explosion and Fire Hazards



⚠ DANGER

Explosion and Fire. Fuel and vapors are extremely flammable and explosive. Add fuel in a well ventilated area. Keep fire and spark away. Failure to do so will result in death or serious injury. (000105)



⚠ WARNING

Fire risk. Fuel and vapors are extremely flammable. Do not operate indoors. Doing so could result in death, serious injury, or property or equipment damage. (000281)



⚠ WARNING

Risk of Fire. Unit must be positioned in a manner that prevents combustible material accumulation underneath. Failure to do so could result in death or serious injury. (000147)

Trailer Hazards

⚠️ WARNING

Trailer must be securely coupled to the hitch and chains correctly attached. Uncoupled or unchained towing could result in death or serious injury. (000233)

⚠️ WARNING

Do not operate this unit while transporting. Doing so could result in death or serious injury. (000231)

⚠️ WARNING

Crushing hazard. Verify unit is properly secured and on level ground. An unsecured unit can suddenly roll or move, causing death or serious injury. (000234a)

⚠️ WARNING

Property or Equipment Damage. Tighten wheel lug nuts after first 50 miles to factory specifications. Failure to do so could result in death, serious injury, property or equipment damage. (000235)

Electrical Hazards

⚠️ DANGER



Electrocution. In the event of electrical accident, immediately shut power OFF. Use non-conductive implements to free victim from live conductor. Apply first aid and get medical help. Failure to do so will result in death or serious injury. (000145)

⚠️ DANGER



Electrocution. Water contact with a power source, if not avoided, will result in death or serious injury. (000104)

⚠️ DANGER



Electrocution. Contact with bare wires, terminals, and connections while generator is running will result in death or serious injury. (000144)

⚠️ DANGER



Electrocution. Verify electrical system is properly grounded before applying power. Failure to do so will result in death or serious injury. (000152)

⚠️ DANGER



Electrocution. Turn utility supply OFF before working on utility connections of the transfer switch. Failure to do so will result in death or serious injury. (000123)

⚠️ DANGER



Electrocution. Never connect this unit to the electrical system of any building unless a licensed electrician has installed an approved transfer switch. Failure to do so will result in death or serious injury. (000150)

⚠️ WARNING



Electrical shock. Disconnect battery ground terminal before working on battery or battery wires. Failure to do so could result in death or serious injury. (000164)

Battery Hazards



⚠ DANGER

Electrocution. Do not wear jewelry while working on this equipment. Doing so will result in death or serious injury.

(000188)



⚠ WARNING

Explosion. Batteries emit explosive gases while charging. Keep fire and spark away. Wear protective gear when working with batteries. Failure to do so could result in death or serious injury.

(000137a)



⚠ WARNING

Explosion. Do not dispose of batteries in a fire. Batteries are explosive. Electrolyte solution can cause burns and blindness. If electrolyte contacts skin or eyes, flush with water and seek immediate medical attention.

(000162)



⚠ WARNING

Risk of burn. Do not open or mutilate batteries. Batteries contain electrolyte solution which can cause burns and blindness. If electrolyte contacts skin or eyes, flush with water and seek immediate medical attention.

(000163a)

⚠ WARNING

Environmental Hazard. Always recycle batteries at an official recycling center in accordance with all local laws and regulations. Failure to do so could result in environmental damage, death or serious injury.

(000228)

Always recycle batteries in accordance with local laws and regulations. Contact your local solid waste collection site or recycling facility to obtain information on local recycling processes. For more information on battery recycling, visit the Battery Council International website at: <http://batteryCouncil.org/>.

Section 2 General Information

Component Locations

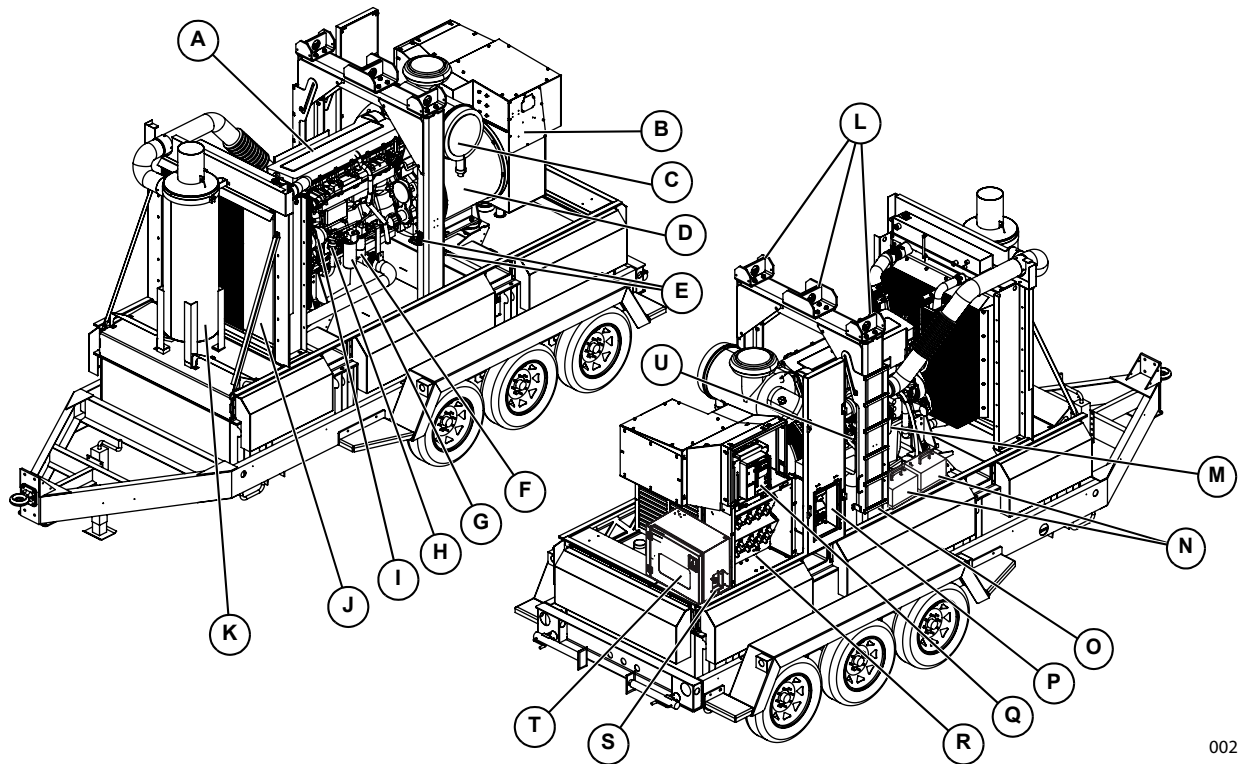

002867

Figure 2-1. Component Locations

Table 2-1. Generator Components

A	Engine	L	Lift Points
B	Generator Box	M	Oil Filter
C	Air Filter	N	12 Volt Batteries (2)
D	Generator	O	Roof Access Ladder
E	Steps	P	Receptacle Box
F	Fuel Filter (primary)	Q	Main Circuit Breaker
G	Fuel Filter (secondary)	R	Lug Box
H	Oil Dipstick	S	Emergency Stop Switch
I	Alternator	T	Control Box
J	Radiator	U	Starter
K	Exhaust Muffler		

Unit and Serial Number Locations

See **Figure 2-2** to locate the unit ID tag (A), located above the controller behind the control door, and Vehicle Identification Number (VIN) tag (B). Important information, such as the unit model number, serial number, VIN and tire loading information is found on these tags. Record the information from these tags so it is available if the tags are lost or damaged. When ordering parts or requesting assistance, you may be asked to provide this information.

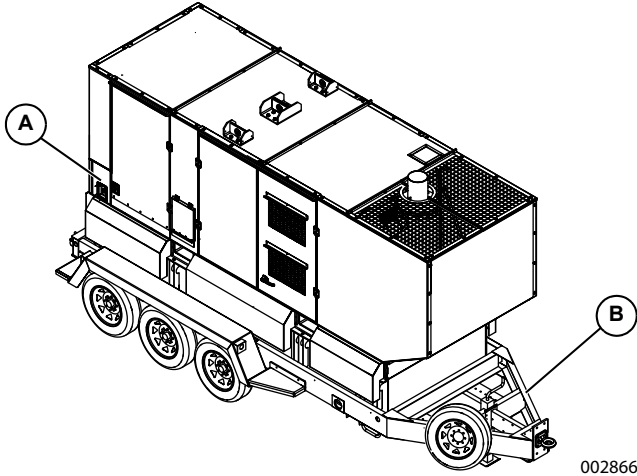

Figure 2-2. Unit and Serial Number Locations

Engine Oil Recommendations

To maintain the product warranty, the engine oil should be serviced in accordance with the recommendations of this manual.

The engine has been filled with factory engine oil of a grade recommended by the engine supplier.

See **Figure 2-3**. Use a high quality detergent oil with an appropriate classification and viscosity for the engine type and ambient temperature conditions. Consult your Generac Mobile Products Authorized Dealer or the applicable engine service manual for engine oil recommendations.

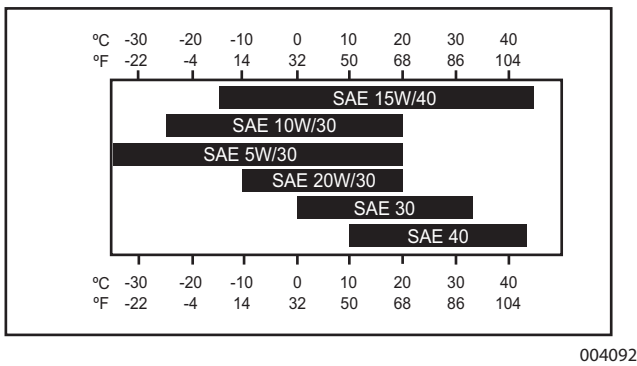

Figure 2-3. Oil Recommendation

Coolant Recommendation



DANGER

Risk of poisoning. Do not use mouth to siphon coolant. Doing so will result in death or serious injury.

(000149)



WARNING

Risk of burns. Do not open coolant system until engine has completely cooled. Doing so could result in serious injury.

(000154)

CAUTION

Do not use any chromate base rust inhibitor with propylene glycol base antifreeze, boosters or additives. Doing so will cause overheating.

(000165)

Consult your Generac Mobile Products Authorized Dealer or the applicable engine service manual for engine coolant recommendations. See table below for mixtures:

Freezing Point °F (°C)	-12 (-24)	-34 (-36)	-54 (-48)	-90 (-67)
Water (% Volume)	60	50	40	30
Antifreeze (% Volume)	40	50	60	70*

* Maximum freeze protection is at 70%.

Control Panel

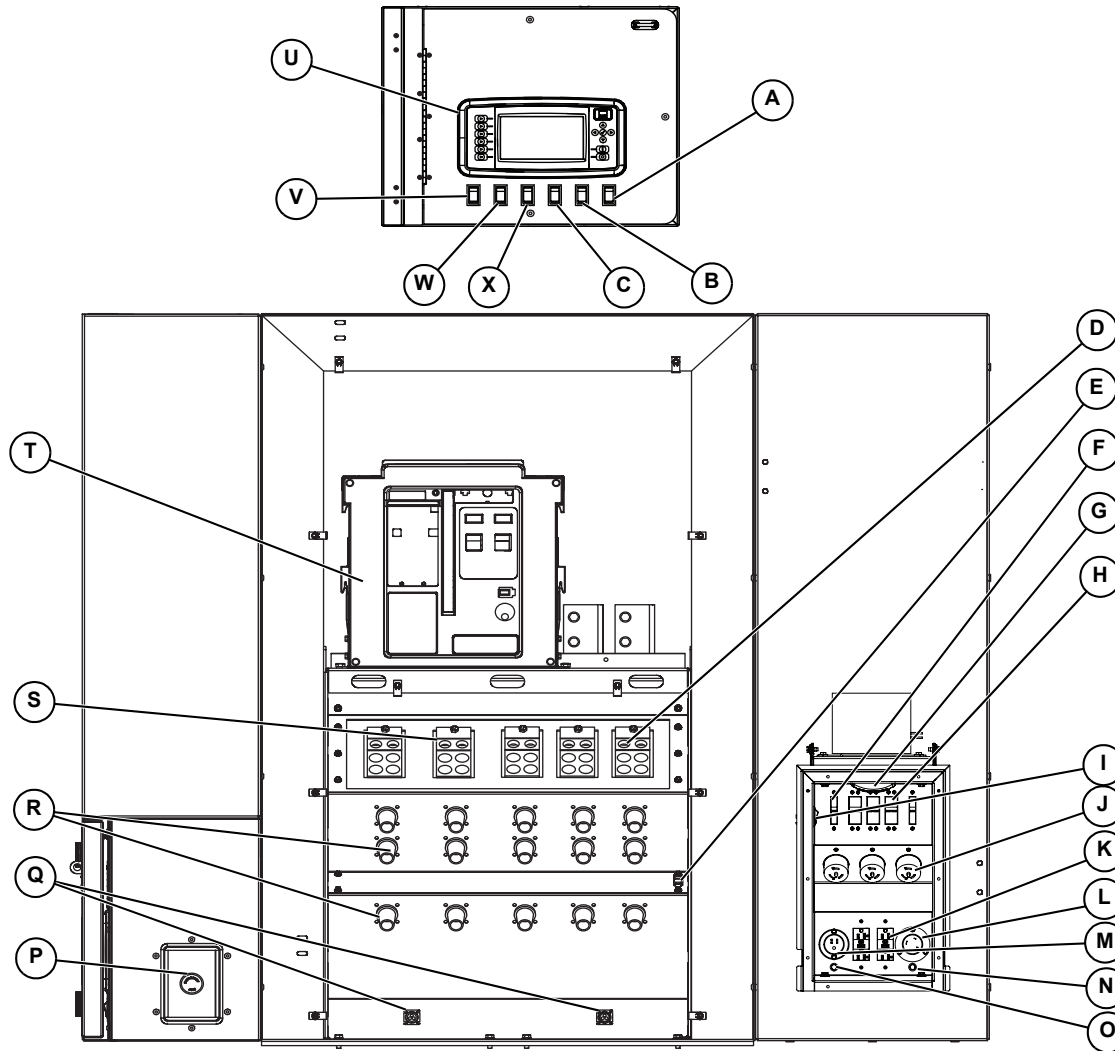

002844

Figure 2-4. Control Panel Component Locations

Table 2-2. Control Panel Components

A	Scene lighting right side switch (optional)	M	120V/15A Edison plug (1)
B	Scene lighting left side switch (optional)	N	30A circuit breaker
C	Interior lights switch	O	15A circuit breaker
D	Output ground connection	P	Emergency stop switch
E	Remote Start Terminal Block	Q	Paralleling CAN receptacles
F	20A circuit breakers (2)	R	Cam lock connectors
G	LED Light	S	Connection terminal lugs (4)
H	50A circuit breakers (3)	T	Generator circuit breaker (GCB)
I	LED ON/OFF Switch	U	PowerZone controller
J	240V twist-lock receptacles (3)	V	Control power switch
K	120V GFCI receptacles (2)	W	Engine idle switch
L	120V/30A Edison plug (1)	X	Fuel transfer switch

PowerZone® Controller

The PowerZone Parallel controller is an AUTO start controller that monitors the unit and indicates operational status and fault conditions. The controller can be programmed to automatically start or stop based on time schedule, fault condition, or load demand.

The controller constantly monitors vital generator and engine functions for a number of preprogrammed alarm and fault conditions. When a fault condition occurs, the engine can be shut down automatically and the display screen will show the fault that caused the shut down. To resume operation, the fault condition must be resolved.

The controller operates the Generator Circuit Breaker (GCB) by sending an open or close signal to the breaker. This is necessary for parallel operations, where the generator and bus voltages need to be synchronized prior to closing the breaker.

NOTE: If the breaker is opened or closed manually using the push buttons on the GCB, the unit will shutdown; only use the controller for GCB operation.

This controller also records a history of unit performance which may be viewed at any time and will not be lost when the controller is powered down.

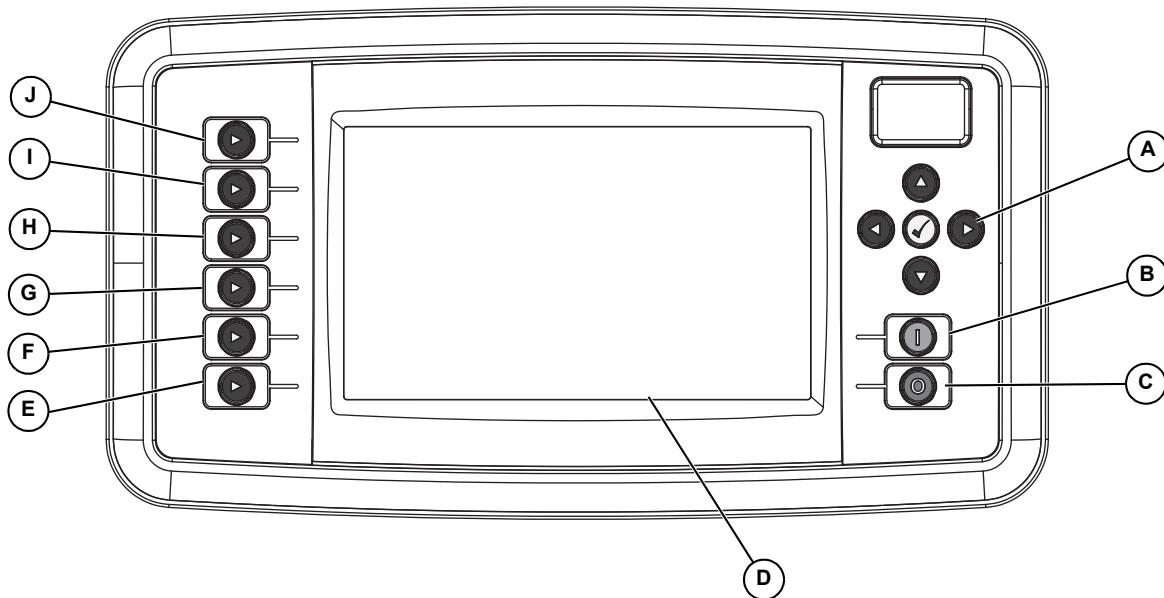

003425

Figure 2-5. PowerZone Controller Layout

Table 2-3. Controller Features

- A Navigation Buttons
- B Engine Start Button
- C Engine STOP/RESET button
- D Display Screen
- E MANUAL mode button
- F AUTO mode Button
- G Alarm Mute Button
- H Open GCB Button
- I Close GCB Button
- J Home Button

Controller Features and Functions

Home Button

The Home (🏠) button is the default screen of the controller and will display after the controller is powered up and the unit management software is loaded. It displays a live readout of the kW meter, percent of load used (gauge), selected phase, volts and amps being produced by the generator, and the fuel level with time until empty. The controller will automatically return to this screen from any other screen after a period of inactivity.

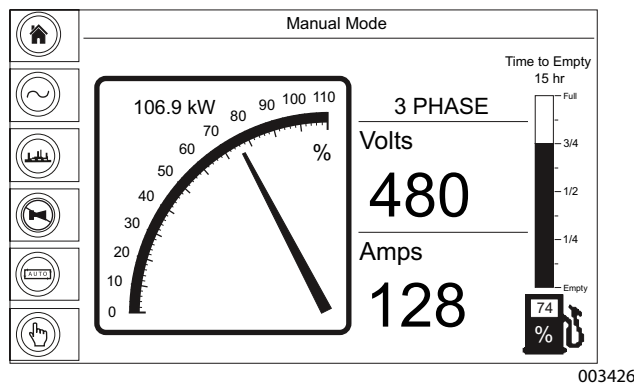

Figure 2-6. Home Button Screen

Close Generator Circuit Breaker (GCB) Button

The Close GCB (⌋) button closes the generator circuit breaker (in MANUAL mode only).

Open Generator Circuit Breaker (GCB) Button

The Open GCB (⌋) button opens the generator circuit breaker (in MANUAL mode only).

Alarm Mute Button

The Alarm Mute (🔇) button silences the audible alarm. Additional action will be required to fully disable the active alarm.

AUTO and MANUAL Mode Buttons

The AUTO and MANUAL Mode buttons change the startup and shutdown mode of the unit. When the AUTO Mode (⏪) button is pressed, the unit enters AUTO mode. When the MANUAL Mode (👉) button is pressed, the unit enters MANUAL mode.

Navigation Buttons

These buttons are used to navigate and interact with the PowerZone Parallel controller screens. Pressing any directional arrow (▲, ▶, ▼, ◀) while on any of the

operator screens will open the maintenance screens and navigate the tabs and pages within the maintenance screens. The Enter (✓) button is used to select menus, confirm alarms, and confirm altered settings.

Control Power Switch

Use this switch to start up and shut down the PowerZone Parallel controller. This switch should not be turned OFF when the unit is running.

Engine Start Button

Pressing the Engine Start (I) button while the controller is in MANUAL mode will start the unit, provided there are no shutdown errors and the engine satisfies the start status. If the controller is in AUTO mode, the Engine Start (I) button has no effect.

Engine STOP/RESET Button

⚠️ WARNING

In case of an emergency, press the emergency stop button to stop the engine immediately. Failure to do so could result in death or serious injury. (000298)

⚠️ CAUTION

Equipment Damage. The emergency stop switch is not to be used to power down the unit under normal operating circumstances. Doing so will result in equipment damage. (000246)

Pressing the Engine STOP/RESET (O) button will shut down the unit and put the controller into STOP mode, whether in MANUAL mode or AUTO mode.

Liquid Crystal Display (LCD)

Displays the various operator and maintenance screens. By viewing these screens, the operator will be able to monitor both the engine and generator status while the unit is running.

Maintenance Screens

All of the data inputs from the engine, generator, inputs/outputs, schedule and PowerZone controller are visible on the maintenance screens.

The information displayed on the maintenance screens can be used to identify, diagnose and troubleshoot unit shutdown conditions and poor unit performance. The maintenance screens can be accessed from any operator screen by pressing any directional arrow (▲, ▶, ▼, ◀).

The bottom of the screens have a list of available tabs, with the currently displayed tab highlighted in blue. The tabs can be selected by using the ► or ◀ buttons. To the left of the tabs, the current/available pages are displayed. The pages within a tab can be viewed by using the ▲ and ▼ buttons. Whenever a new tab is selected, the current page will always be page one.

Generator Summary

The Generator Summary can be found at the top of all maintenance screens and provides an overview of the system.

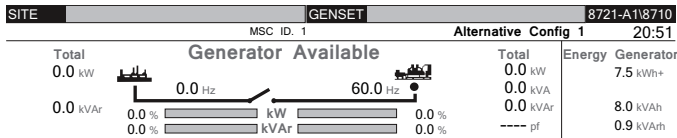

Figure 2-7. Generator Summary Screen

Home Tab

The Home tab is automatically displayed when no other page has been selected after a period of inactivity, or when the operator selects the Home tab.

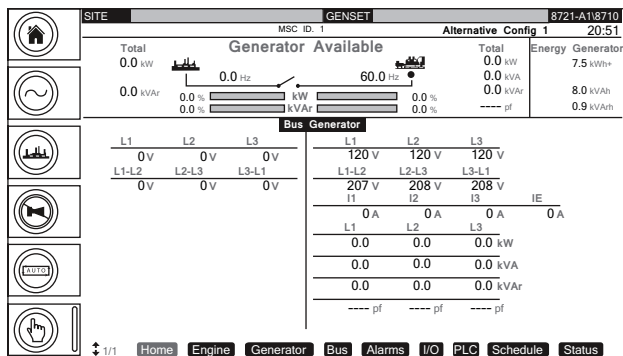
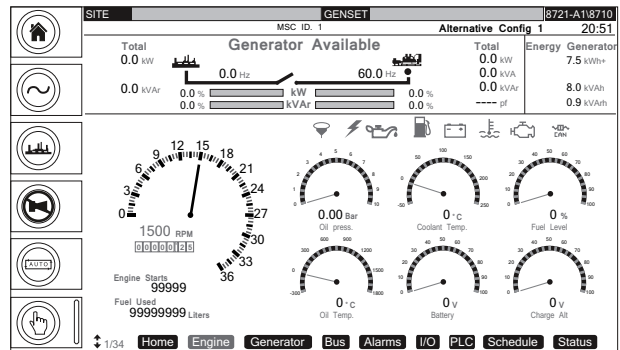

Figure 2-8. Home Tab Screen

Engine Tab

The Engine tab contains maintenance and instrumentation data gathered from the engine. Above the engine analogue meters is a row of alarm icons. Each icon can be one of three colors: gray (inactive), yellow (warning) or red (shutdown). The alarm icons are as follows from left to right: water in fuel, charge alternator, oil pressure, fuel level, battery voltage, coolant temperature, ECU lamp and CAN link status.

NOTE: The content may change depending upon the selected engine and the features supported by the engine.



002847

Figure 2-9. Engine Tab Screen

Generator Tab

The Generator tab contains maintenance and instrumentation data gathered from the generator. Each page highlights different data gathered by the generator, with the analogue meters changing accordingly. The last two pages will display the information in the bar graph. The bar graph shows blue for positive and red for negative. For the power factor bar graph, blue is for lagging pf and red is for leading pf.

NOTE: The content may change depending upon the selected generator and the features supported by the generator.

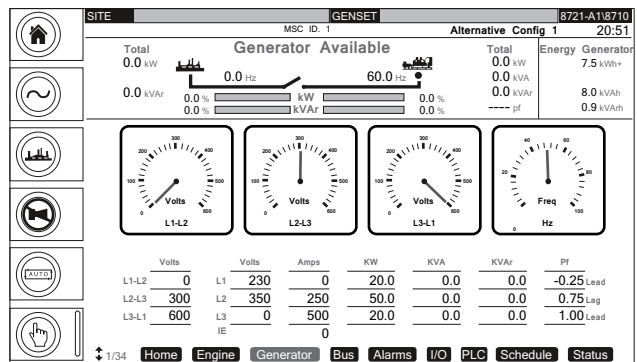

002848

Figure 2-10. Generator Tab Screen

Bus Tab

The Bus tab displays the voltage and frequency values of the bus.

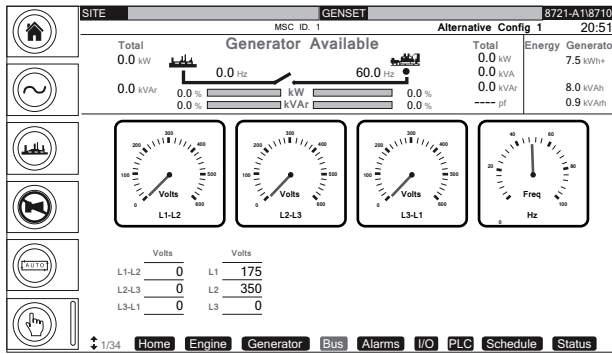

002849

Figure 2-11. Bus Tab Screen

Alarms Tab

The Alarms tab displays warnings, electrical trip, shutdown alarms and any engine Diagnostic Trouble Codes (DTC) that are occurring or have occurred previously. The first page on the Alarms tab displays the alarms that are currently active. They are organized by alarm type.

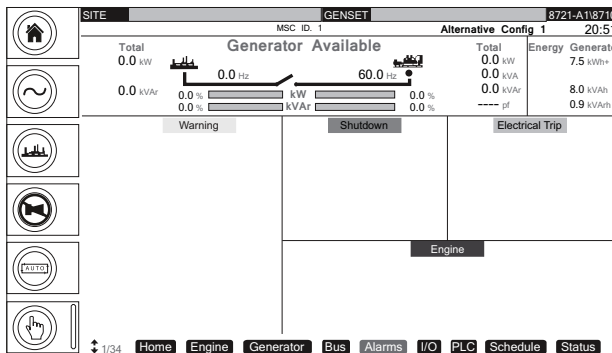

002850

Figure 2-12. Alarms Tab Screen (Page One)

Table 2-4. Diagnostic Trouble Codes

Alarm Type	Color - Background/Text	Graphic
Warning	Yellow/Black	Warning
Electrical Trip	Purple/Black	Electrical Trip
Shutdown	Red/Black	Shutdown
ECU Code	Blue/White	Engine

The second page of the Alarms tab shows the event log with a list of events, including normal operation events and alarm notifications, with the most recent events at the top of the list. All indexed events include the date and time of the event, hours of runtime on the engine when it occurred, along with the event name or alarm type and details.

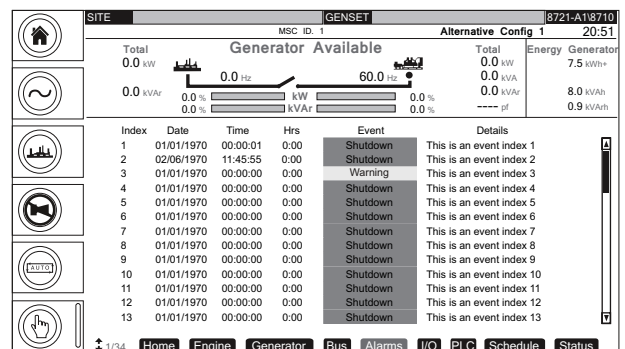

002851

Figure 2-13. Alarms Tab Screen (Page Two)

To scroll down within the event log, press the Enter (✓) button. The scroll bar will change to blue, signifying it is active. Press the ▲ or ▼ buttons to scroll up or down in the event log. When finished, press the Enter (✓) button again.

Input/Output Tab

The Input/Output (I/O) tab shows a list of digital inputs and outputs connected to the controller, whether they are active and the current state (open/closed status) of the input and output.

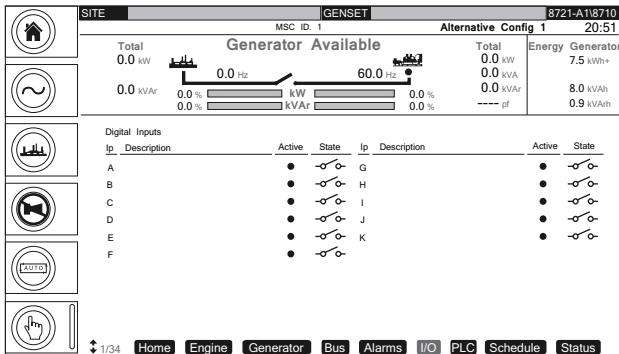

Figure 2-14. Input/Output Tab Screen

PLC Tab

The PLC tab displays all the PLC counters and registers.

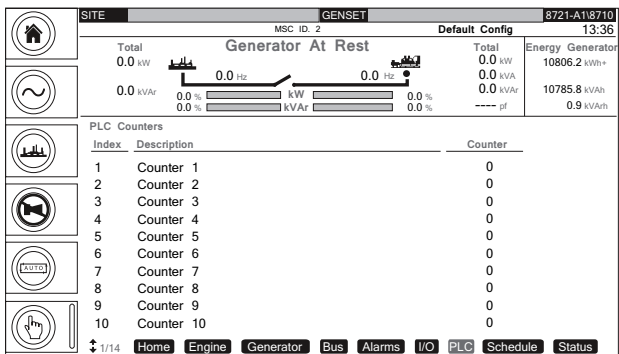

Figure 2-15. PLC Tab Screen

Schedule Tab

The Scheduler tab shows the current configuration and status of the scheduler, located below the generator summary. The maintenance configuration status and time remaining until an alarm, electrical trip or shutdown will be displayed at the bottom of the screen. The lamp(s) to the left shows the configuration status of the maintenance alarm, not the alarm condition.

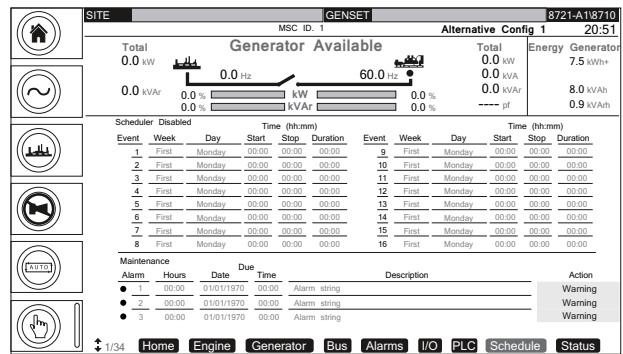

Figure 2-16. Schedule Tab Screen

Status Tab

The Status tab contains the status and configuration of the controller, firmware and data connections.

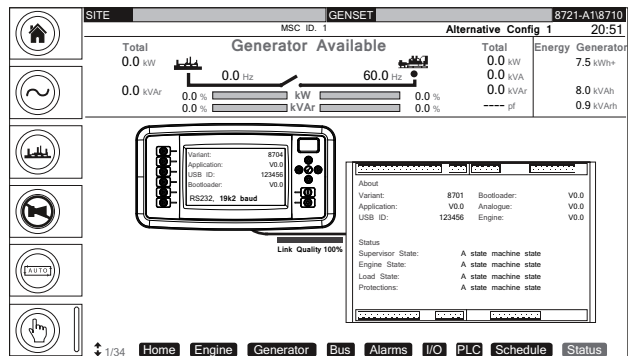

Figure 2-17. Status Tab Screen

Controller Information Displays, Functions, and Reset

The PowerZone controller constantly monitors vital generator and engine functions for a number of operation, alarm and fault conditions. When a fault condition occurs, the engine will shut down automatically and the main display will show the fault that has caused the shutdown. To resume operation, the fault condition must be resolved. To reset the controller and resume operation, press the Enter (✓) button.

Belt Tensioner

The Volvo engine includes an automatic tensioner that cannot be adjusted or repaired and is designed to maintain proper tension over the belt's life. Inspect units according to the manufacturer's specifications.

Optional Equipment

Shorting (Link) Board Option

The output voltage can be changed by moving the shorting (link) board in the generator reconnect box. The reconnect box is located on the top of the generator. Before attempting to change the output voltage, shut the generator down and make sure that the generator circuit breaker and the control power switch are in the OFF (O) position/state.



DANGER

Electrocution. Lethal voltage may be present at connection lugs. Do not change the voltage while the engine is running. Doing so will result in death or serious injury. (000309)

To receive 480 3Ø voltage at the connection lugs, the shorting (link) board must be attached in the lower position as shown in the illustration. For 208 3Ø voltage, the shorting (link) board must be in the upper position as shown in the illustration. If the board needs to be changed from one setting to the other, remove all of the 1/2 in. nuts that hold the shorting (link) board down and move it to the new position. Replace all of the hardware and tighten it to 25 ft-lbs. of torque. Reinstall the reconnect box door and start the generator by following the [Prestart Checklist](#).

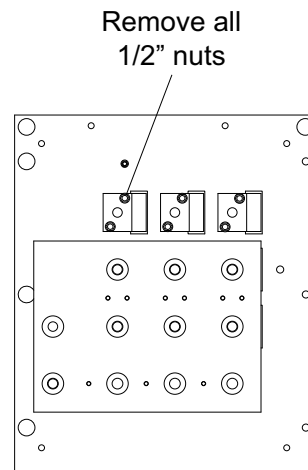
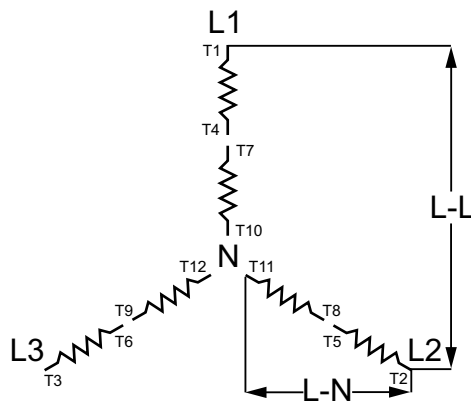

Link Board Attached in 480 Volt 3Ø Position

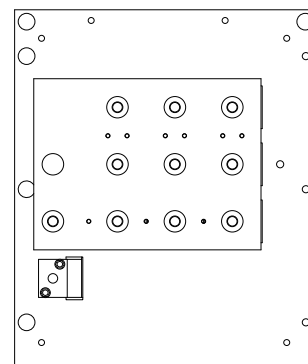
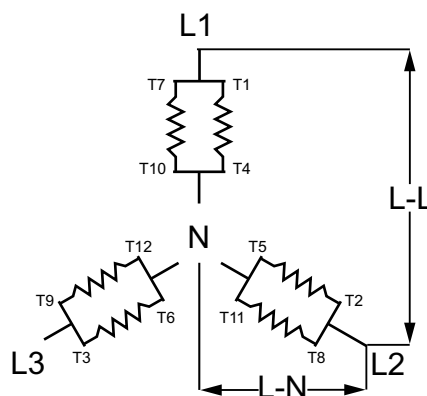

Link Board Attached in 208 Volt 3Ø Position

002856

Figure 2-18. Shorting (Link) Board

This page intentionally left blank.

Section 3 Operation

Prestart Checklist

Before starting the unit, all items in the prestart checklist must be completed. This checklist applies to both manual and remote starting of the unit.



WARNING

Consult Manual. Read and understand manual completely before using product. Failure to completely understand manual and product could result in death or serious injury. (000100a)

- Verify all maintenance procedures are up to date. For more information, see [General Maintenance](#) and [Basic Maintenance Schedule](#).
- The unit must be level.
- Verify there is no water inside, on, or near the unit; dry if needed.
- For grounding requirements, follow any local, state, or National Electrical Code (NEC) guidelines.
- Verify the Control Power switch is OFF (O).
- Verify all circuit breakers are OFF (O).
- Inspect all electrical cords; repair or replace any that are cut, worn, or bare.
- Verify oil, coolant, and fuel levels are correct, per the engine manufacturer manual.
- Verify battery connections are secure.
- Verify all electrical connections at the connection lugs, if equipped, are tight and wired correctly.
- Turn the battery disconnect switch ON, if equipped.
- Inspect the engine fan belt tension and condition.
- Inspect the engine fan guard.
- Inspect the engine exhaust system for loose or rusted components.
- Verify the radiator and surrounding shroud are clear of debris.
- Verify all covers are in place and secure.
- Verify the emergency stop switch is pulled out.

Manually Starting the Unit



DANGER

Asphyxiation. Running engines produce carbon monoxide, a colorless, odorless, poisonous gas. Carbon monoxide, if not avoided, will result in death or serious injury. (000103)

All units equipped with the PowerZone controller will initially start up in STOP mode. Use the following procedure to start the generator in MANUAL mode:

1. Move the Control Power switch to ON (I).

2. The display screen will show the prestart diagnosis and the controller will load the unit management software.

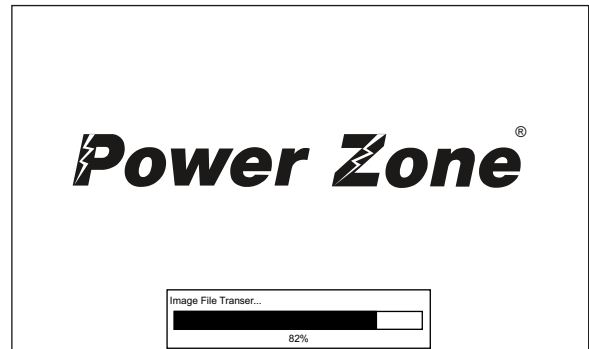

002804

Figure 3-1. Prestart Screen

3. When the software is loaded, the Home screen will be displayed and the controller will be in STOP mode as indicated at the top of the screen. Press the MANUAL Mode (I) button to enter MANUAL mode.

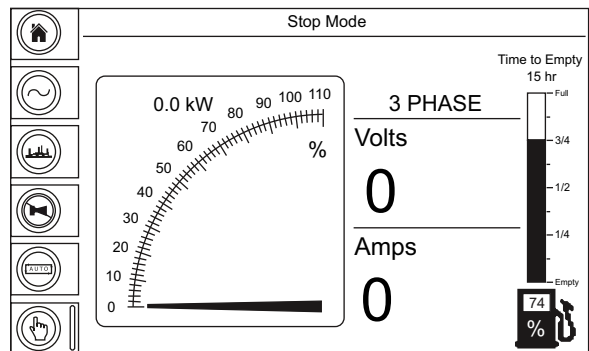

002805

Figure 3-2. Home Screen

NOTE: The engine can be started from any screen when it is in MANUAL mode.

4. Pressing the green Engine Start (I) button on the controller will initiate the startup procedure and start the engine, provided there are no engine faults preventing the unit from starting.

NOTE: It may take a few seconds for the engine to run smoothly and reach its governed operating speed. During this time, the screen will show a voltage different from that set with the voltage selector switch.

5. If the engine does not start after the first cranking attempt, the engine will pause for 15 seconds to allow the starter to cool. The display screen will show MANUAL MODE - CRANK REST at the top

of the screen. The engine will make two more attempts to start for a total of three crank cycles.

6. Should the engine not start and run within three crank cycles, the display screen will show the FAIL TO START alarm. The starting sequence may be repeated after the starter has had a minimum of two minutes to cool. Pressing the Enter (✓) button will clear the alarm and reset the controller.

NOTE: The engine controller may skip the preheat engine steps on some of the larger models.

7. Once the engine starts, it will immediately begin speeding up to a constant 1800 rpm. The engine may hunt or change speeds until operating speed is reached. After a few minutes of operation, the engine will be warmed up and the operator screens will show engine and generator operating parameters.
8. Check the generator for excessive noise or vibration and any coolant, oil, or fuel leaks before applying any loads.
9. Verify the AC output voltage is correct.
10. Check that the frequency (Hz) is correct on the Generator screen. With no loads connected to the generator, the frequency should read approximately 60 Hz, depending on the type of engine governing used.
11. If all wiring connections have been made correctly, switch the main circuit breaker to ON (I) and then add any loads attached to the receptacles by switching the respective circuit breaker to ON (I). You will notice a slight change in engine sound when a load is applied to the unit.

AUTO (Remote) Starting the Unit

AUTO mode is used when the unit is started from a location other than the control panel by using a transfer switch. AUTO (remote start) is the normal setting when the unit is being used as a standby power supply. Before putting the unit in AUTO mode, review [Prestart Checklist](#) and [Manually Starting the Unit](#). Follow all safety warnings and review all information on isolating the generator with a transfer switch if the unit is to be used as a standby power supply.

1. Perform a manual start of the unit at least once to verify that the engine is operating correctly.
2. If a check of the remote start circuit is desired, remove the wires from the remote start terminal block. Press the AUTO Mode () button, the display screen should show AUTO MODE at the top of the screen. Attach a jumper wire (minimum 16 gauge) across the two terminals on the remote start terminal block. This applies a ground to the PowerZone Controller to close the starting circuit contacts. The engine should crank, start and run.

3. Remove the jumper wire from the remote start terminal block and the engine will stop. Reconnect any necessary wires from the remote start switch (transfer switch) to the remote start terminal block.
4. Verify the unit is in AUTO mode. The display screen should show AUTO MODE at the top of the screen.
5. Close the main circuit breaker (set to ON (I)).
6. Secure the unit by closing and locking all access doors.
7. The unit is now ready for remote starting.

See [Figure 3-3](#). The remote start terminal block provides a connection for installation of a remote start switch which will allow the unit to be started by a remote dry-contact closure switch. For location of the remote start terminal block, see [Control Panel](#).

Before entering AUTO mode, verify the contacts on any remote switch linked to the unit are open. If the contacts on a remote switch are closed, the engine will crank and start when AUTO mode is entered. Attach the switch leads to the two unused terminals (A) on the unit's remote start terminal block.

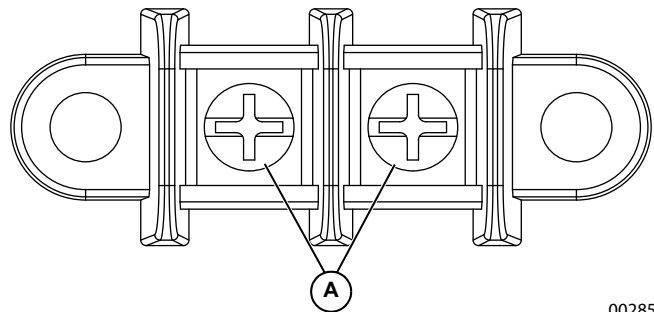

002857

Figure 3-3. Remote Start Terminal Block

Parallel Setup and Operation

This unit can be operated in parallel with other parallel-capable units. To verify the units to be used in parallel are compatible and appropriate for the load, contact Generac Mobile Products Technical Service at 1-800-926-9768.

Before running units in parallel, verify each unit is operating properly according to this manual. The units in parallel can be set up in AUTO or MANUAL mode, as long as all the units are set up in the same mode. See [Manually Starting the Unit](#) or [AUTO \(Remote\) Starting the Unit](#) for more information.

Each unit is equipped with two CAN receptacles, used to connect units for parallel operation, located on the control panel. The CAN link cable and two 120Ω resistor plugs are provided with each unit.



Figure 3-4. Two Units in Parallel

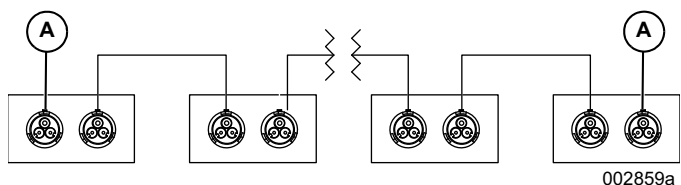



Figure 3-5. Three or More Units in Parallel

A	120Ω resistor
---	---------------

See [Figure 3-4](#) and [Figure 3-5](#). Insert the provided link cable into a CAN receptacle on each unit. Insert the provided 120Ω resistor plug into the unused CAN receptacle on each end unit.

If the units are running in MANUAL mode, the generator circuit breaker must be manually opened and closed using the controller. To synchronize the units, press , after the SAFETY ON DELAY, to close the breaker. Press  to open the breaker and disconnect the unit from being in parallel with the other unit(s).

If the units are running in AUTO mode, the breakers will automatically open and close.

Once the units are set up in parallel, they will share any load evenly during normal operation. If parallel units are in AUTO mode and one unit is shut down, the full load will transfer to the remaining units. If all parallel units are in MANUAL mode and stop is pressed, the load gradually transitions to the other units.

NOTE: If one or more units shuts down unexpectedly, any remaining unit will shut down if the increased proportional load is greater than the remaining units are rated for. Contact Generac Mobile Products Technical Service to verify the units to be used in parallel are appropriate for the planned load.

Ladder Operation

The ladder, located on the right side of the unit, is used for climbing to the roof of the unit for maintenance, lift eye access and radiator access.

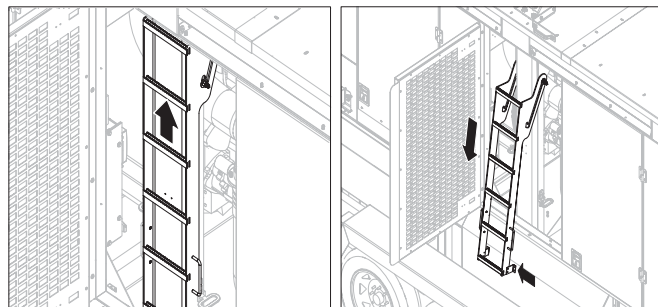

Figure 3-6. Ladder Operation

Use the following procedure to prepare the ladder for use:

1. Lift the ladder up until the bend of the ladder guide is reached.
2. Pull the ladder out and away from the unit until it is fully extended.
3. Rest the rubber bumpers of the ladder onto the rain guard panel.

Door Latch Operation

The latches used to open the enclosure doors have a button (A) located behind the handle that must be pressed to operate. This button also has a hole for attaching a padlock.

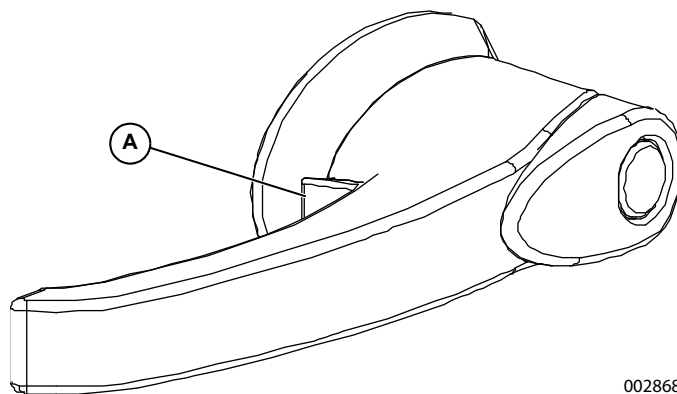

Figure 3-7. Door Latch

NOTE: The enclosure doors cannot be opened without holding down the latch button.

Viscous Fan Clutch

The viscous fan clutch option allows the engine cooling fan to disengage at lower temperatures and engage at higher temperatures, increasing cooling system efficiency. The cooling fan will engage at full speed when the coolant temperature rises. When the fan is operating at full speed, it will switch to a slower speed when the coolant temperature drops. There will be an audible difference when the engine cooling fan switches speeds. Depending on unit model, the coolant temperature ranges vary between 170°F and 185°F (77°C and 85°C).

Wet Stacking

The unit is powered by a diesel engine. Diesel engines are susceptible to wet stacking if lightly loaded. Wet stacking occurs when an engine is run at less than 30% of its full load capacity, causing unburned fuel to accumulate in the exhaust system. Wet stacking can be detected by continuous black exhaust when the unit is under a constant load. It can also cause fouling of injectors and buildup on engine valves. Diesel engines operate properly when applied loads are between 30% and 100% capacity. Appropriate generator sizing is

determined by the anticipated load. If the unit is in a wet stack condition, load the unit heavily for five hours or until the exhaust is clear.

Engine Derating

All units are subject to derating for altitude and temperature. Derating reduces the available power for operating tools and accessories connected to the outlets. For every increase in 1000 ft (305 m) of elevation, engine performance for this unit typically drops between 2% and 4%. Maximum operating temperature is 115°F (46°C).

Cold Starting Operation

The engine is equipped with an air intake manifold heater that is directly controlled from the engine controller. It is designed to preheat incoming air for up to 30 seconds prior to cranking the engine. Depending on ambient temperature it is also recommended to use additional winter package accessories to aid cold starting. The use of a block heater and oil pan heater are also recommended at -20°F (-28°C) and colder.

Table 3-8. Cold Starting Operation

Time from start to stay within 0.5% of no load speed at ambient temperature:	68°F (20°C)	8.4 seconds @ 1800 rpm
	41°F (5°C)	8.7 seconds @ 1800 rpm
	5°F (-15°C)	9.8 seconds @ 1800 rpm
Time from start to stay within 0.8% of no load speed at ambient temperature:	68°F (20°C)	7.5 seconds @ 1800 rpm
	41°F (5°C)	8.2 seconds @ 1800 rpm
	5°F (-15°C)	9.2 seconds @ 1800 rpm
* With manifold heater kW engaged, lubrication oil 10W/30, block heater and MK1 fuel.		
Usage of manifold heater:	Time preheating	30 seconds
	Time post heating	1 minute 42 seconds
Ambient temperature	5°F (-15°C)	
Block heater type and make	HOTSTART	
Power kW	2.5	
Heating hours	4	

Generator Output Connections



⚠ DANGER

Electrocution. Do not disable or modify the connection box door safety switch. Doing so will result in death or serious injury.

(000157)



⚠ DANGER

Electrocution. Before connections are made to the unit, verify the main circuit breaker and battery disconnect switch are OFF. Failure to do so will result in death or serious injury.

(000156)

⚠ DANGER

Electrical backfeed. Use only approved switchgear to isolate generator from the normal power source. Failure to do so will result in death, serious injury, and equipment damage.

(000237)

⚠ WARNING

Only a trained and licensed electrician should perform wiring and connections to unit. Failure to follow proper installation requirements could result in death, serious injury, and damage to equipment or property.

(000155)

Installation should be in compliance with the national electrical code (NEC), state and local regulations.

The unit is equipped with connection lugs, located on the lower portion of the control box behind the lug box door. The lugs provide connection points for attachment of external loads to the generator. A large decal on the inside of the connection lug door details the proper connections for selected voltages.

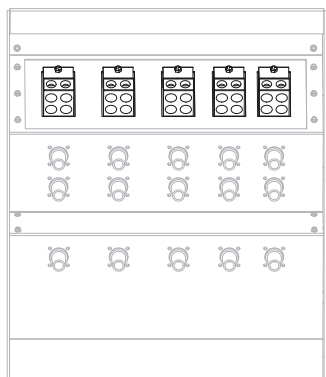

002861

Figure 3-9. Connection Lugs

Connections to the lugs should be made by running the power cables up through the opening in the bottom of the box.

IMPORTANT NOTE: Do not make any connections directly to the lugs without routing the cables through the opening. Use a hex-wrench to tighten the cable connections.

The lug box door is equipped with safety interlock switches that will trip the main circuit breaker and disable the voltage regulator if the door is opened while the unit is operating.

A ground connection is located next to the connection lugs. The unit must be connected to ground for proper operating safety. The generator neutral is bonded to ground when it is shipped from the factory. The bonding plate will need to be removed when the generator is used as a standby power source.

Generator Cam Lock Connections



⚠ DANGER

Electrocution. Before connections are made to the unit, verify the main circuit breaker and battery disconnect switch are OFF. Failure to do so will result in death or serious injury.

(000156)

⚠ DANGER

Electrical backfeed. Use only approved switchgear to isolate generator from the normal power source. Failure to do so will result in death, serious injury, and equipment damage.

(000237)



⚠ WARNING

Electric Shock. Verify all connections to the cam lock receptacles are made to one row only. Failure to do so could result in death, serious injury and property damage.

(000356)

⚠ WARNING

Only a trained and licensed electrician should perform wiring and connections to unit. Failure to follow proper installation requirements could result in death, serious injury, and damage to equipment or property.

(000155)

The unit is equipped with cam lock connections, located behind the lug box door below the connection lugs. These receptacles provide connection points for the attachment of external loads to the generator. A large decal on the inside of the connection lug door details the proper connections for selected voltages.

Connections should be made by plugging power cables

equipped with series 16 taper nose 400A/600V cam lock plugs into the cam lock receptacles. Secure the connection by rotating the plug a 1/2 turn to the right. The lug box door is equipped with safety interlock switches that will trip the generator circuit breaker and disable the voltage regulator if the door is opened while the unit is operating.

L1	Black
L2	Red
L3	Blue
N (Neutral)	White
G (Ground)	Green

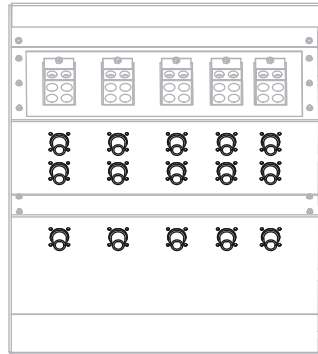

002862

Figure 3-10. Cam Lock Connections



⚠ DANGER

Electrocution. Do not disable or modify the connection box door safety switch. Doing so will result in death or serious injury.

(000157)

A ground connection is located on the far right of the cam lock panel. The unit must be connected to ground for proper operating safety. The generator neutral is bonded to ground when it is shipped from the factory. The bonding plate will need to be removed when the generator is used as a standby power source. Installation should be in compliance with the National Electrical Code (NEC), state and local regulations.

Voltage Regulator

This unit is equipped with a Marathon DVR2000E+ digital voltage regulator (DVR). The voltage regulator controls the output of the generator by regulating the current into the exciter field. The DVR is powered by a single phase permanent magnet generator (PMG). See the Marathon DVR operating manual provided with the unit for more information.

Customer Convenience Receptacles

⚠ CAUTION

Equipment Damage. Verify voltage application before making changes to factory settings. Incorrect voltage applied to a load could result in equipment damage. (000303)

The generator is equipped with five receptacles. The large receptacles are 240V twist-lock receptacles rated at 50A each. The smaller duplex receptacles are 120VAC rated at 20A each with Ground Fault Circuit Interrupt (GFCI) protection. These receptacles are not routed through the main circuit breaker. Each receptacle has its own circuit breaker. Refer to the decal, located above the breakers, to know which breaker corresponds to which receptacle. Each breaker is sized to the maximum rating of the corresponding receptacle.

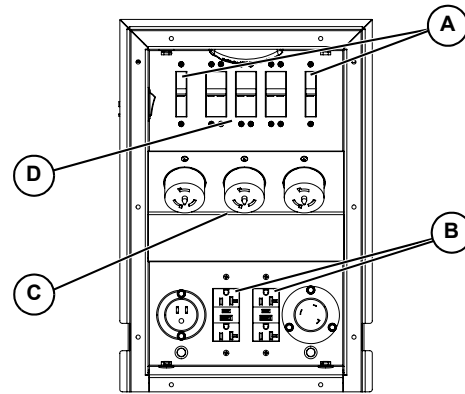

002863

Figure 3-11. Receptacle and Breaker Locations

A	20A Circuit Breakers (2)
B	120V GFCI Receptacles (2)
C	240V Twist-Lock Receptacles (3)
D	50A Circuit Breakers (3)

NOTE: Power to the receptacles is available any time the generator is running, even if the main circuit breaker is OFF (O). Verify equipment connected to the receptacles is turned OFF before turning the breakers ON.

Main Circuit Breaker

See [Figure 3-12](#). The main circuit breaker is located inside the right rear door of the generator enclosure. When the breaker is OFF (O), power is interrupted to the connection lugs, the cam lock receptacles, and the generator. Once the connections have been made to the connection lugs or the cam lock receptacles, and the unit has been started and allowed to reach normal operating temperature, the breaker may be switched ON (I).

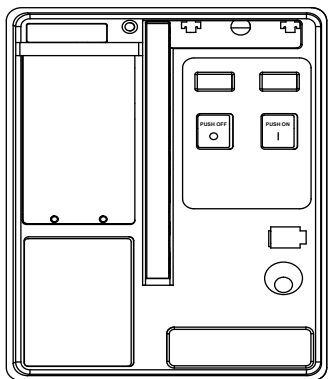

002864

Figure 3-12. Main Circuit Breaker

The main circuit breaker will be tripped, disconnecting power to the connection lugs and the cam lock receptacles if any of the following items occur while the unit is running:

- Overload of the generator circuits to the connection lugs or the cam lock receptacles.
- The door covering the connection lugs and the cam lock receptacles is opened.
- If the emergency stop switch is activated.

Verify any problems that cause the main circuit breaker to trip are corrected before returning the switch to ON (I).

NOTE: The main circuit breaker interrupts power to the connection lugs and the cam lock receptacles only. The customer convenience receptacles have power even if the main circuit breaker is OFF (O). To disconnect power to these receptacles, use the individual circuit breakers located near each receptacle.

Transfer Switch

⚠ DANGER

Loss of life. Property damage. Installation must always comply with applicable codes, standards, laws and regulations. Failure to do so will result in death or serious injury. (000190)

⚠ DANGER

Electrical backfeed. Use only approved switchgear to isolate generator from the normal power source. Failure to do so will result in death, serious injury, and equipment damage. (000237)

⚠ WARNING

Only a trained and licensed electrician should perform wiring and connections to unit. Failure to follow proper installation requirements could result in death, serious injury, and damage to equipment or property. (000155)



⚠ WARNING

Phase rotation between transfer switch and power lines must be compatible. Incompatible phase rotation could result in equipment damage, death or serious injury. (000226)

Installation should be in compliance with the National Electrical Code (NEC), state and local regulations.

Before any connections are attempted, verify the main circuit breaker and the Control Power switch are in the OFF (O) position and that the negative (-) battery cable has been disconnected from the battery.

Installation of such devices must be performed by following all directions supplied by the manufacturer of the switch. If attaching the unit to a power supply normally serviced by a utility company, notify the utility company and check state and local regulations. Familiarize yourself with all instructions and warning labels supplied with the switch.

When the unit is used as a standby power supply, it must be equipped with a transfer switch which isolates it from the utility's distribution system. A transfer switch is designed to transfer electrical loads from the normal power source (utility) to the emergency power source (generator) when normal voltage falls below a prescribed level. The transfer switch automatically returns the load back to the normal source when power is restored back to operating levels.

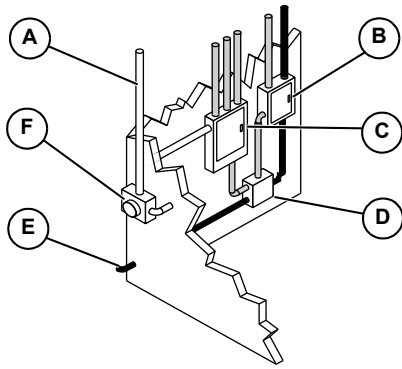

002807

Figure 3-13. Transfer Switch Operation

A	Incoming Utility Power
B	Emergency Distribution Panel (Generator Power)
C	Main Distribution Panel (Utility Power)
D	Transfer Switch
E	Power From Generator
F	Utility Meter
WHITE	Incoming Utility Power
GRAY	Normal Utility Power Circuit
BLACK	Emergency Generator Power Circuit

AUTO Exercise Timer

The PowerZone controller is capable of starting and stopping the unit automatically, based on a programmable schedule.

Units installed in a standby application should be exercised regularly to maintain operating condition and to ensure responsiveness in an emergency situation. Use the following procedures to operate the unit in AUTO mode:

Accessing the Configuration Menu

1. With the unit stopped, press ▲, ►, ▼, or ◀ to navigate to the maintenance screens from any of the operator screens.
2. While on any maintenance screen, press ✓ and O simultaneously. The controller will display the Configuration menu.
3. To save any changes and exit the Configuration menu, press and hold ✓ for five seconds. To cancel any changes and return to the maintenance screen, press and hold O for five seconds.

Set the Controller Clock

The schedule runs based off the time set in the controller clock. Use the following procedure to set the controller clock before setting the schedule:

1. Navigate to the Maintenance group and press ► to access it.
2. Press ► to select the Time section.
3. Set the time and date to the correct local time.

Set the Schedule

NOTE: The controller must be in AUTO mode to run at the programmed time. Use a trickle or solar battery charger to prevent the controller from draining the battery while in AUTO mode.

1. Access the Scheduler group by pressing the ► button.

NOTE: The Scheduler group is made up of the Scheduler Options and Scheduler Setup sections. Each section can be accessed and exited using the ► and ◀ buttons.

2. Access the Scheduler Options section. Within this section, the scheduler can be enabled, RUN mode selected, and load mode selected.

Table 3-1. Scheduler Options

Item	Values
Enable	Yes/No
Run Mode	Monthly/Weekly
Load	Idle, In Island, On Load, Off Load

3. Access the Scheduler Setup section. Within this section, each schedule entry can be modified by pressing the ✓ button to select the item and the ▲ and ▼ buttons to define them.

Table 3-2. Scheduler Setup

Item	Values
Schedule Entry	1-16
Start Time	00:00-23:59
Duration	00:00-99:59
Day	Monday-Sunday
Week (of month)	First, Second, Third, Fourth

Setting Up a Daily Scheduled Run

1. Enable the Scheduler.
2. Set RUN mode to Weekly.
3. Set Load to preferred method.
4. Set the Start Time and Duration for seven days (Monday - Sunday).
5. Set the controller to AUTO mode.

Set the Unit to AUTO Mode

From any screen, press the AUTO Mode () button to enter AUTO mode. AUTO mode will be displayed at the top of the screen.

NOTE: If any of the scheduled time slots are currently active, the controller will begin the starting sequence and start the unit, provided there are no shutdown conditions present.

Shutting Down the Unit

Prior to shutting down the unit, check with personnel using power supplied by the generator and let them know that the power is going to be turned off. Verify the power shut down will not create any hazards by accidentally turning off equipment that needs to be kept on (pumps, compressors, lights, etc.).

1. Remove all loads from the generator by opening all circuit breakers (turn OFF (O)).
2. Let the engine run for approximately five minutes to allow it to cool down.
3. Press the red Engine STOP/RESET (O) button on the controller. This will result in the generator going into the shutdown cycle and starting a 15 second shutdown timer called stopping. If the unit does not shut down within 15 seconds, a stop fail alarm will be displayed on the display screen.
4. After the unit shuts down, move the Control Power switch to OFF (O).

NOTE: For extended storage time, disconnect the battery. See the engine operator's manual for extended storage requirements.

Emergency Stop Switch



In case of an emergency, press the emergency stop button to stop the engine immediately. Failure to do so could result in death or serious injury. (000298)



Equipment Damage. The emergency stop switch is not to be used to power down the unit under normal operating circumstances. Doing so will result in equipment damage. (000246)

The unit is equipped with one emergency stop switch. For location of the emergency stop switch, see [Component Locations](#). The switch can be accessed and activated with all doors closed and locked.

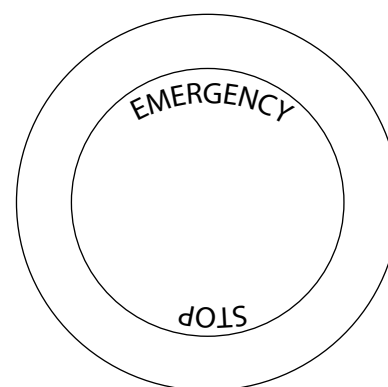

002815

Figure 3-14. Emergency Stop Switch

Activate the emergency stop switch by pushing the button in until it locks down. This will trip the main circuit breaker which will open the contact, disconnecting the load to the connection lugs. This will also open the fuel circuit, shutting down the engine. The emergency stop fault will be displayed on the control panel. The switch will remain closed until it is pulled out.

Towing the Unit

Once the engine is shut down, follow these steps to prepare the unit for towing.

1. Verify the unit is OFF.
2. Use the jack to raise or lower the trailer onto the hitch of the towing vehicle. Lock the hitch coupling and attach the safety chains or cables to the vehicle. Raise the jack foot completely.
3. Connect any trailer wiring to the tow vehicle. Check for proper operation of the directional and brake lights.
4. Verify all doors are properly latched.

5. Check for proper inflation of the trailer tires. Proper inflation is specified on each tire.
6. Check the wheel lugs. Tighten or replace any lugs that are loose or missing. If a tire has been removed for axle service or replaced, tighten the lugs, in the order shown, to the following specifications:
 - a. Start all lug nuts by hand.
 - b. First pass tighten to 20-25 ft-lbs (27-33 Nm).
 - c. Second pass tighten to 50-60 ft-lbs (67-81 Nm).
 - d. Third pass tighten to 90-120 ft-lbs (122-162 Nm).

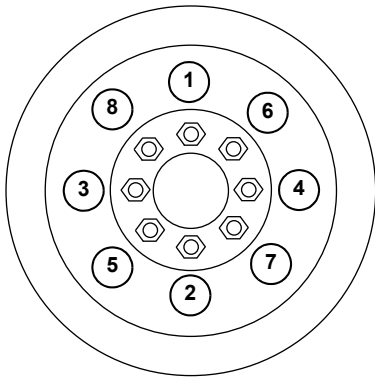

Figure 3-15. Lug Sequence

001441

NOTE: After first road use, repeat tightening procedure.

Maximum recommended speed for highway towing is 45 mph (72 km/h). Recommended off-road towing speed is not to exceed 10 mph (16 km/h).

Lifting the Unit



Personal injury. Excessive weight. Use only appropriate lifting eyes and lifting equipment to lift unit. Improper lifting techniques could result in equipment damage, death or serious injury. (000224)

Lift points (A) are located on the top of the unit and connected to a lift structure inside the unit. Attach a sling or hook to the lift points only if the devices are in good condition and the equipment being used to raise the unit has sufficient capacity. The unit can also be lifted by a forklift, with sufficient capacity, using the forklift pockets (B). For approximate weights, see the applicable product spec sheet. Always remain aware of people and objects around when moving or lifting the unit. Keep the doors closed and locked.

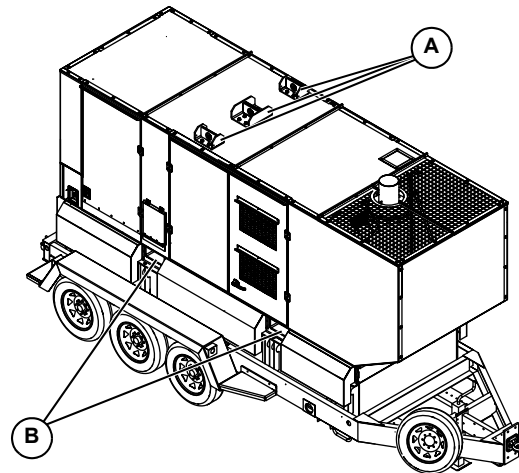

Figure 3-16. Lift Points

002866

Section 4 Maintenance

Emissions Information

For emissions information, see the OEM engine manual.

Daily Walk Around Inspection



Equipment Damage. Failure to perform a daily inspection could result in damage to the unit.

(000306)

Look for conditions that could hinder performance or safety, such as (but not limited to) oil, coolant and fuel leakage, blocked vents, loose or missing hardware, and electrical connections.

Visually inspect the fan belt for cracks, fraying, stretching, and verify the belt is properly seated in the pulley grooves. Replace the belt according to the engine manufacturer's recommendations.

NOTE: At the 500 hour or 12 month service interval, it is recommended that the belt be removed and checked for wear. While the belt is removed, inspect pulleys and bearings. Rotate and feel for hard turning or unusual sounds. If pulleys or bearings need replacement, contact the engine manufacturer.

General Maintenance

Poorly maintained equipment can become a safety hazard. In order for the equipment to operate safely and properly over a long period of time, periodic maintenance and occasional repairs are necessary. Never perform routine service (oil and oil filter changes, cleaning, etc.) unless all electrical components are shut OFF. Before servicing the unit, always follow the instructions listed below.

- Verify the Control Power switch is OFF (O).
- Verify the circuit breakers are OFF (O).
- Activate (push in) the emergency stop switch.
- Disconnect the negative (-) terminal on the battery.
- Attach a DO NOT START sign to the control panel. This will notify everyone that the unit is being serviced and will reduce the chance of someone inadvertently trying to start the unit.
- Do not wash the unit with a high pressure hose or with any kind of power washer.
- Do not wash the engine block or fuel tank with a power washer or steam cleaner. Water may enter the cabinet and collect in the generator windings or other electrical parts, causing damage. Water will also pool on top of fuel tank and mix with any environmentally hazardous fluids that may be present, such as engine oil and coolant.

- If the unit is stored outside, check for water inside the cabinet and generator before each use. If wet, dry the unit thoroughly before starting.
- Inspect condition of electrical cords. **DO NOT** use the unit if insulation is cut or worn through.
- Verify the condition of the air filter by viewing the level of the vacuum draw on the filter minder gauge. Replace the air filter when the yellow center bar reaches the red section on the gauge (20 in. H₂O).
- Check wheel lugs. see [Towing the Unit](#).
- Check coolant level daily. See the engine operator's manual for coolant recommendations and proper mixture.
 - Coolant is checked visually by inspecting the level in the coolant overflow jug located near the radiator.
 - Normal operating level is between the FULL and ADD markings on the overflow jug, also known as the normal range.
 - When engine is stopped and completely cool, coolant may be added directly to the coolant overflow jug.
- Check the oil level daily. See the engine operator's manual for the proper viscosity grade of oil, including special operating conditions such as a change in season or climate.
 - Do not start the unit if the engine oil level is below the add mark on the dipstick.
 - Normal operating level is in the cross-hatch pattern between the FULL and ADD markings on the dipstick.
 - Add oil only if the oil level is below the ADD mark on the bottom of the cross-hatch pattern on the dipstick.
 - Do not overfill the crankcase.
- Check the fuel level.
- If the unit is connected to a remote start or transfer switch, verify the remote switch is also OFF and tagged.

NOTE: If the engine was run out of fuel or the fuel tank was drained, it may be necessary to bleed the fuel lines. See the engine operator's manual supplied with the unit for more information.

Basic Maintenance Schedule

See the engine manual for a complete list of maintenance requirements. Failure to comply with the procedures as described in the engine operator manual will nullify the warranty, decrease performance and cause equipment damage or premature equipment failure. Maintenance records may be required to complete a warranty request.

Table 4-1. Basic Maintenance Schedule

Item	First Service*	Every 500 Hrs.	Every 1000 Hrs.	Every 2000 Hrs.	Every 4000 Hrs.	Every 8000 Hrs.
Clean fuel pre-filter and drain water	◆	◆				
Inspect with VODIA (diagnostic tool)	◆	◆				
Inspect coolant and cooling system	◆	◆				
Inspect drive belt and tensioner	◆	◆				
Inspect for abnormal engine noises and leaks	◆	◆				
Check tire pressure	◆	◆				
Lubricate leveling jacks	◆	◆				
Check oil pressure	◆	◆				
Replace engine oil and engine oil filters**	◆	◆				
Inspect air filter		◆				
Drain fuel tank and inspect		◆				
Inspect radiator		◆				
Inspect batteries		◆				
Replace air filter			◆			
Replace fuel filters			◆			
Replace fuel filter and pre-filter			◆			
Inspect hoses, cables and clamps				◆		
Inspect engine - cleaning and painting				◆		
Adjust valve clearance				◆		
Inspect and clean turbocharger				◆		
Replace drive belts					◆	
Replace coolant (green)					◆	
Replace coolant (yellow)						◆

* First service at 100 hrs to 200 hrs.

** See [Table 4-2](#) for more information.

Special Service Intervals

Table 4-2. Special Maintenance Schedule

Item	Service Interval
Replace engine oil, engine oil filters and bypass filter	Every 50-600 hrs. Oil change intervals are dependent on oil grade and sulfur content of fuel. See the engine manual for complete information.
Oil analysis	Check with local Volvo dealer.

Engine Break-In Requirements

NOTE: During the first 10 hours of operation, avoid long periods of no load or sustained maximum load operation or long stretches at constant load. If the generator is to run for longer than five minutes without a load, shut the generator down.

Higher engine oil consumption is normal during the first 100-200 hours of operation. During this period and after ten hours of operation, check the oil level frequently.

Operate the engine at heavy loads (60-90% of maximum) as much as possible. If the engine has spent significant time at idle, constant load(s), or light load, or if makeup oil is required, a longer break-in period may be needed. See the engine operator's manual for a full description of necessary procedures on the extension of the break-in period. For more information on regular maintenance intervals, see [Basic Maintenance Schedule](#).

Resetting the Maintenance Alarms

The PowerZone controller will display a warning message when the unit is due for maintenance or service. The maintenance or service interval is set at 250, 500 and 3000 hours of engine running time. Once the unit has been serviced, the appropriate maintenance alarm reminder needs to be reset. The following procedure demonstrates how to reset the maintenance alarms:

1. With the unit shut down, move the Control Power switch to CONTROL ON (I). After initialization, the controller will toggle automatically to the Home screen.
2. Press ▲, ►, ▼, or ◀ to enter the maintenance screens.
3. Press ✓ and O simultaneously. The next screen will display the Configuration menu.
4. Press ▼ to move the cursor (blue highlighted text) down to the Maintenance group.
5. Press ► to access the sections. Press ▼ to highlight the Maintenance section.
6. Press ► to access the parameters and highlight the maintenance alarm that needs to be reset.
7. Press ✓ to select the editable parameters. The cursor will highlight NOT RESET under the selected maintenance alarm. Press ▲ to highlight RESET.
8. Press ✓ to reset the selected maintenance alarm.
9. To perform additional maintenance alarm resets, repeat steps 6-8.

NOTE: If the selected maintenance alarm does not need to be reset, press ▼ to highlight NOT RESET and press ✓ to return to the parameters section.

10. To save changes, press and hold ✓ for five seconds. To discard changes made, press and hold O for five seconds.

Checking Generator Drive Plate Torque

Follow the procedure below to check the torque of the generator drive plate bolts in accordance with the maintenance chart.

1. Disconnect battery.
2. Remove generator fan guard.
3. Tighten each of the drive plate bolts to the appropriate specification shown in the table below.

Table 4-3. Drive Plate Bolt Torques

Unit	ft-lbs (Nm)
MMG625VT2	80 (108)

4. Install generator fan guard.
5. Connect battery.

Jack Maintenance

The following procedures should be performed annually.

Side-Wind Models

- The internal gearing and bushings of the jack must be kept lubricated. Apply a small amount of automotive grease to the internal gearing by removing the jack cover, or if equipped, use a needle nose applicator or standard grease gun on the lubrication point found on the side of the jack near the crank. Rotate the jack handle to distribute the grease evenly.
- A lightweight oil must be applied to the handle unit at both sides of the tube.
- If equipped, the axle bolt and nut assembly of the caster wheel must also be lubricated with the same lightweight oil.

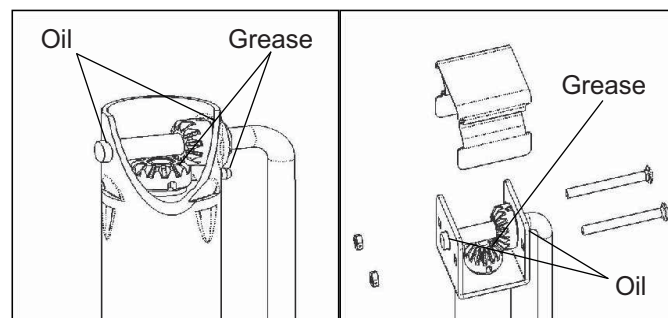

002823

Figure 4-1. Lubrication Points (Side-Wind Models)

Top-Wind Models

- Apply a lightweight oil to the screw stem.

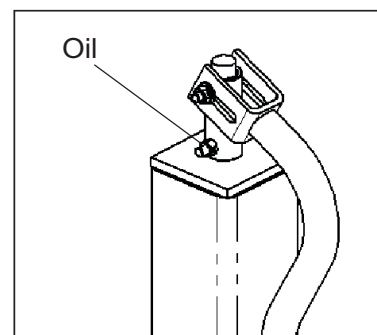

002865

Figure 4-2. Lubrication Points (Top-Wind Models)

Trailer Wheel Bearings

The trailer axles are equipped with a grease fitting to allow lubrication of the wheel bearings without the need to disassemble the axle hub. To lubricate the axle bearings, remove the small rubber plug on the grease cap, attach a standard grease gun fitting to the grease fitting and pump grease into the fitting until new grease is visible around the nozzle of the grease gun. Use only a high quality grease made specifically for lubrication of wheel bearings. Wipe any excess grease from the hub with a clean cloth and replace the rubber plug when finished. The minimum recommended lubrication is every 12 months or 12,000 miles (19,312 km). More frequent lubrication may be required under extremely dusty or damp operating conditions.

Section 5 Troubleshooting

General Troubleshooting

This information is intended to be a check or verification for simple causes that can be located and fixed. It does not cover all types of problems. See the engine operator’s manual for additional troubleshooting information. Procedures that require in-depth knowledge or skills should be referred to a trained technician.

Table 5-1. General Troubleshooting Guide

Problem	Cause	Solution
Low Fuel Level Shutdown	Low fuel level	Check fuel level in display screen of controller.
	Unit not level	Verify unit is sitting level to ensure an accurate reading.
	Fuel tank leaking	Check tank for leaks.
	Damaged fuel sender or wiring	Check for continuity between sender and engine controller. (See DC Wiring .)
Low Oil Pressure Shutdown	Low oil level	Check oil level on dipstick. Add oil if needed.
	Oil leaking from engine	Visually inspect the engine for leaks. Restart unit and verify loss of pressure. Shut down immediately if pressure does not reach 5 psi (34 kPa) within five seconds.
	Oil pressure sender	See engine operator’s manual to identify corrective action.
Low Coolant Level Shutdown	Low coolant level	Allow engine to cool, then check coolant level in radiator. Add coolant if needed.
	Coolant hoses leaking	Inspect hoses for leaks. Repair or replace as necessary.
	Engine block or water pump leaking	Visually inspect for leaks. Verify no coolant has mixed with the engine oil (oil will appear milky). See engine operator’s manual for additional information.
High Coolant Temperature Shutdown	Low coolant level	Add coolant if needed. Allow engine to cool, then check coolant level in radiator. Restart engine and check coolant temperature (on controller). Stop engine immediately if coolant temperature is 210°F (99°C) or more.
	Blockage in radiator	Check radiator shroud and ducting for blockage and remove any foreign matter.
	Leakage in coolant hoses, engine block, or water pump	Inspect for visible leaks. Check tension of water pump serpentine drive belt. Remove load on generator and restart engine. Check coolant temperature and shut engine down immediately if it starts to overheat (230 degrees or higher). See the engine operator’s manual for additional information on engine overheating.
Overcrank Shutdown	Fuel level low	Check fuel level in tank. Check fuel pump operation. Check air filter for blockage. See engine operator’s manual for additional information.
Overspeed or Underspeed Shutdown	Frequency setting incorrect	Disconnect all loads and restart unit. Read frequency (Hz) in the display screen on controller. Frequency should read 60 Hz. If frequency is above 60 Hz, engine speed will need to be adjusted. See the engine operator’s manual for throttle adjustment information.

This page intentionally left blank.

Section 6 Wiring Diagrams and Service Log

AC Wiring

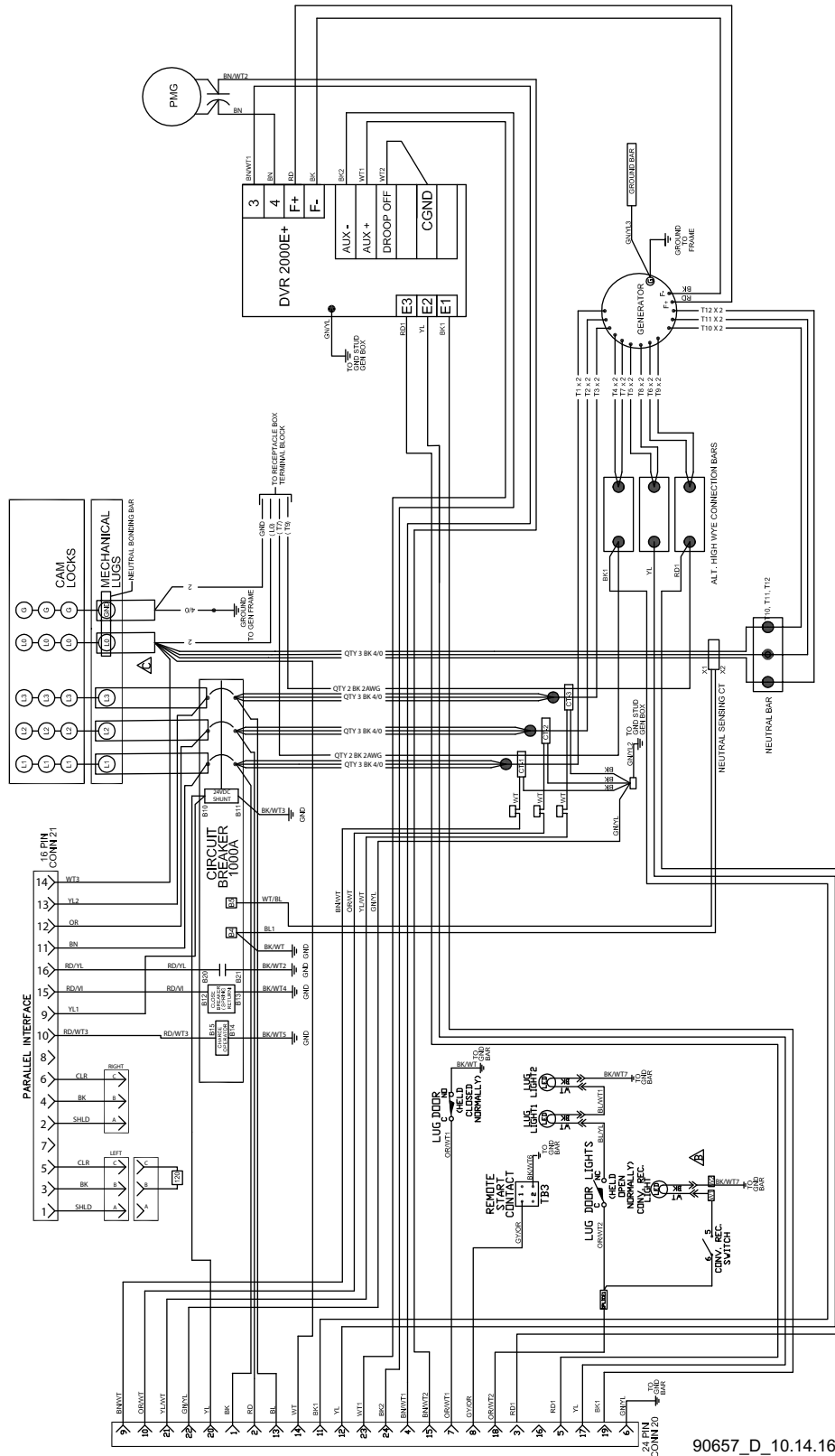

90657_D_10.14.16

AC Wiring - Control Panel Receptacles

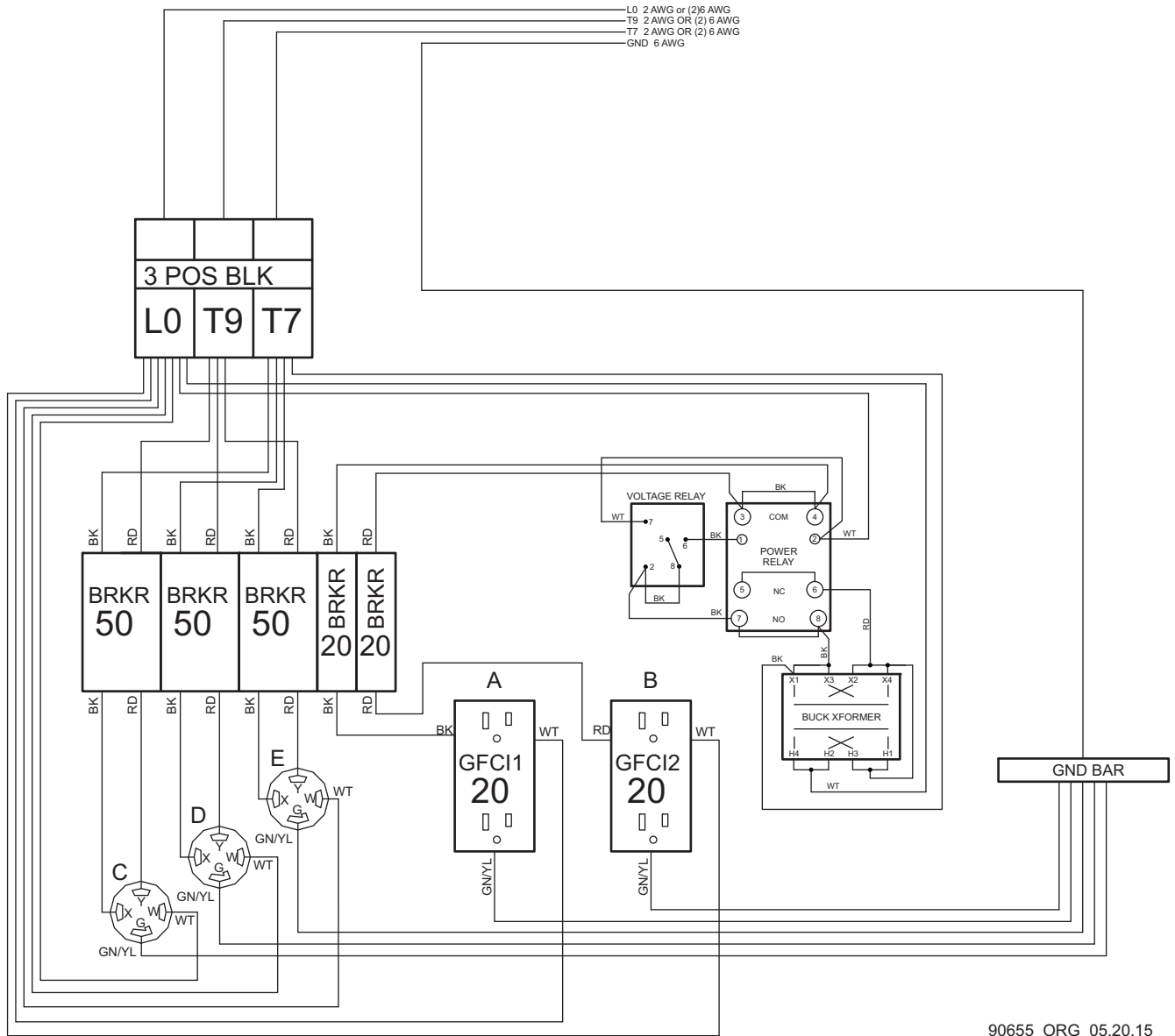

90655_ORG_05.20.15

AC Wiring - Link Board Option

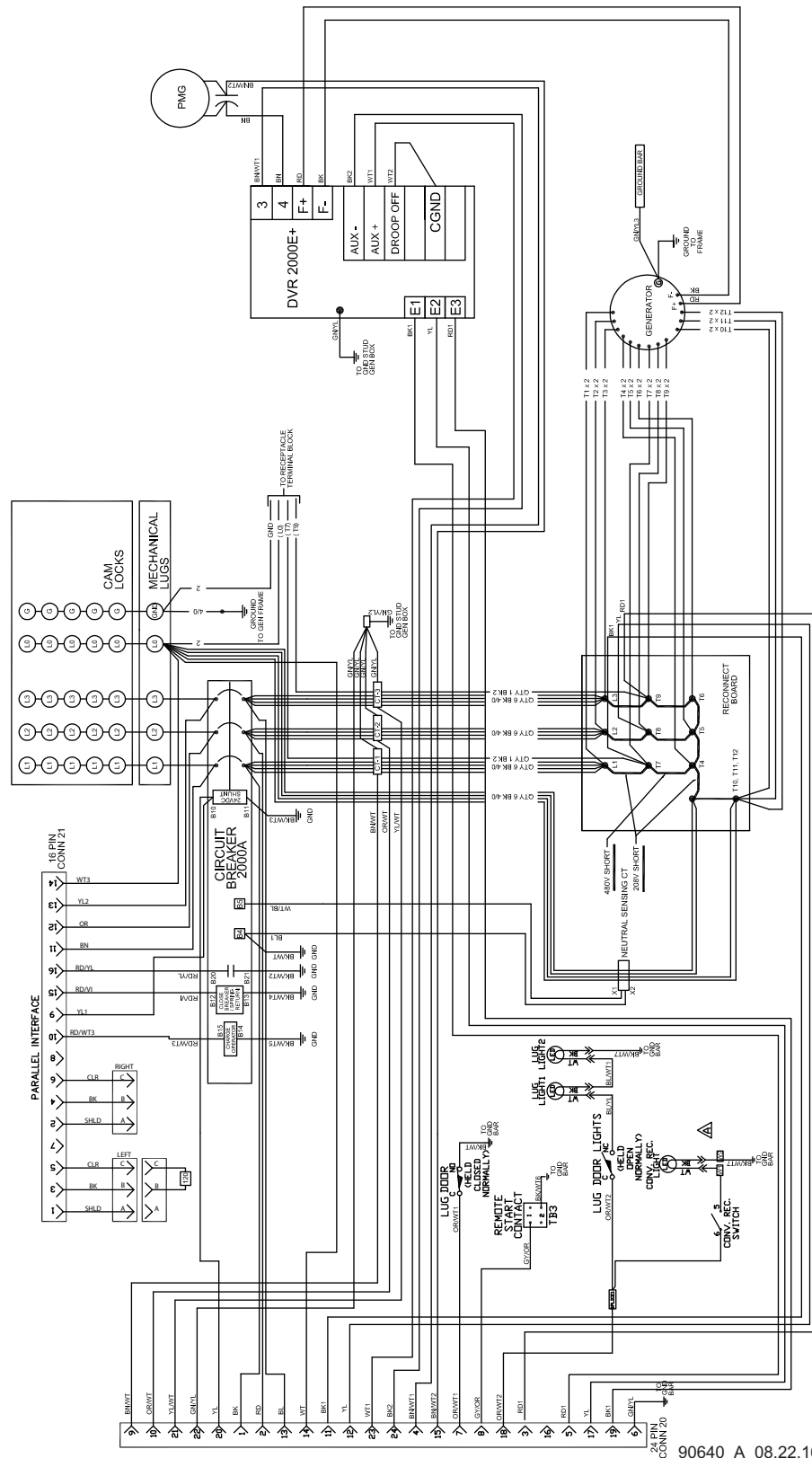

90640_A_08.22.16

DC Wiring

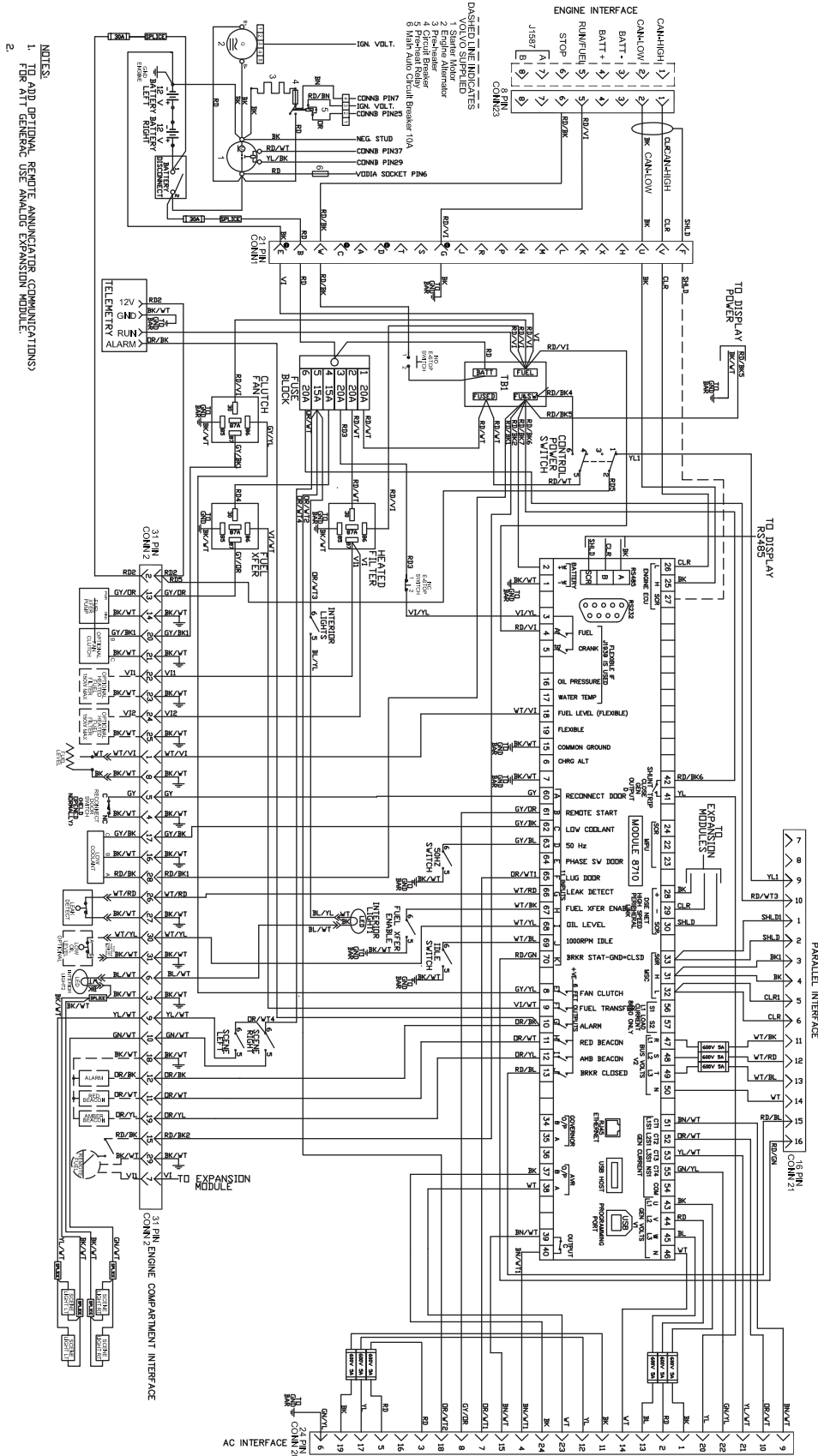

90638_D_10.12.16

Engine and Power Wiring (1 of 2)

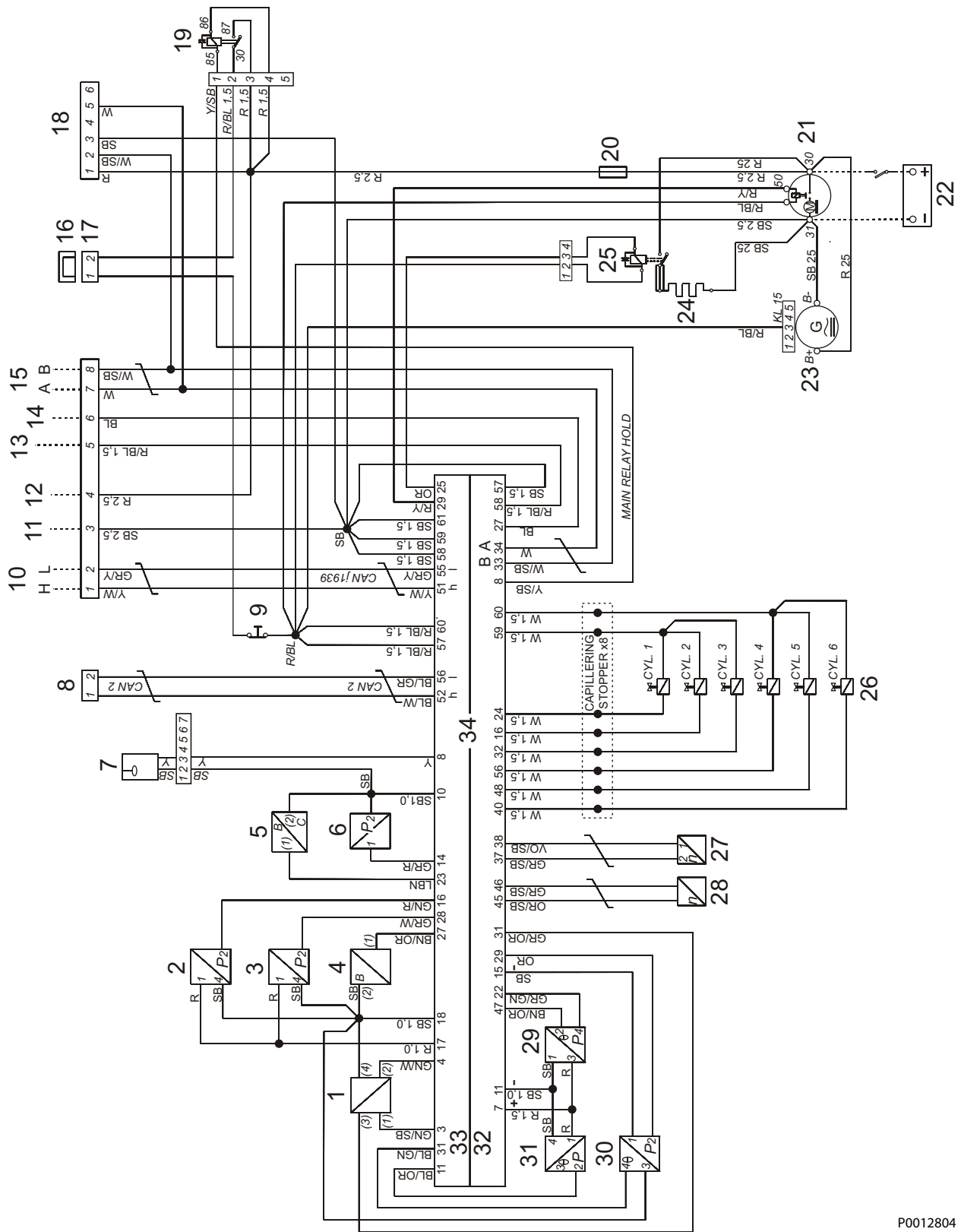

P0012804

Engine and Power Wiring (2 of 2)

1	Sensor, oil level	19	Main relay
2	Sensor, fuel pressure	20	Main circuit breaker 10 A
3	Sensor, crankhouse pressure	21	Starter motor
4	Sensor, coolant temperature	22	Battery (24 V)
5	Sensor, coolant level	23	Alternator
6	Piston cooling pressure sensor	24	Pre-heating
7	Sensor, water in fuel	25	Relay pre-heating
8	Connector (not used)	26	Unit injector (Cyl. 1-6)
9	Extra stop	27	Sensor, flywheel
10	J1939 CAN (bus)	28	Sensor, camshaft
11	Battery negative	29	Sensor, charge air pressure/temperature
12	Battery plus	30	Air filter indicator
13	Voltage after key	31	Sensor, oil pressure
14	Stop button (press button)	32	Connector A
15	J1587 (bus)	33	Connector B
16	Jumper	34	Control unit, EMS 2
17	Aux stop	35	Connector (not in usej)
18	VODIA output		

Cable colors

BL	=	Blue
LBL	=	Light blue
BN	=	Brown
LBN	=	Light brown
GN	=	Green
GR	=	Grey
OR	=	Orange
P	=	Pink
R	=	Red
SB	=	Black
VO	=	Purple
W	=	White
Y	=	Yellow

Cable cross section = 0.75 mm² unless otherwise stated.

DC Wiring - Battery Charger

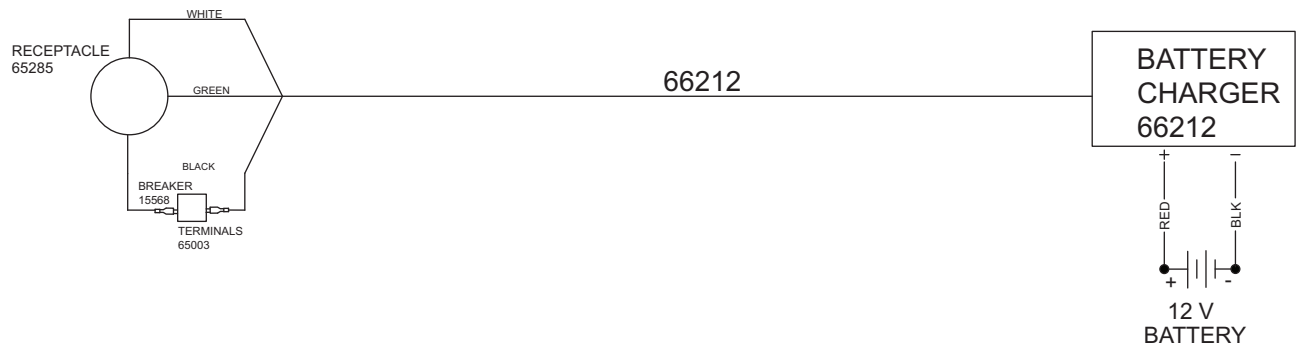

90593_B_09.19.16

DC Wiring - Engine Heater

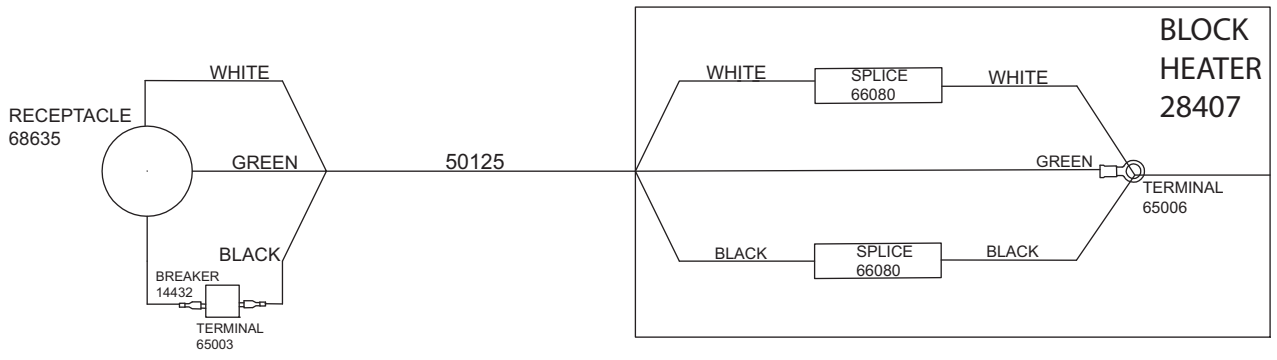

90594_C_07.21.16

DC Wiring - Remote Communication (Optional)

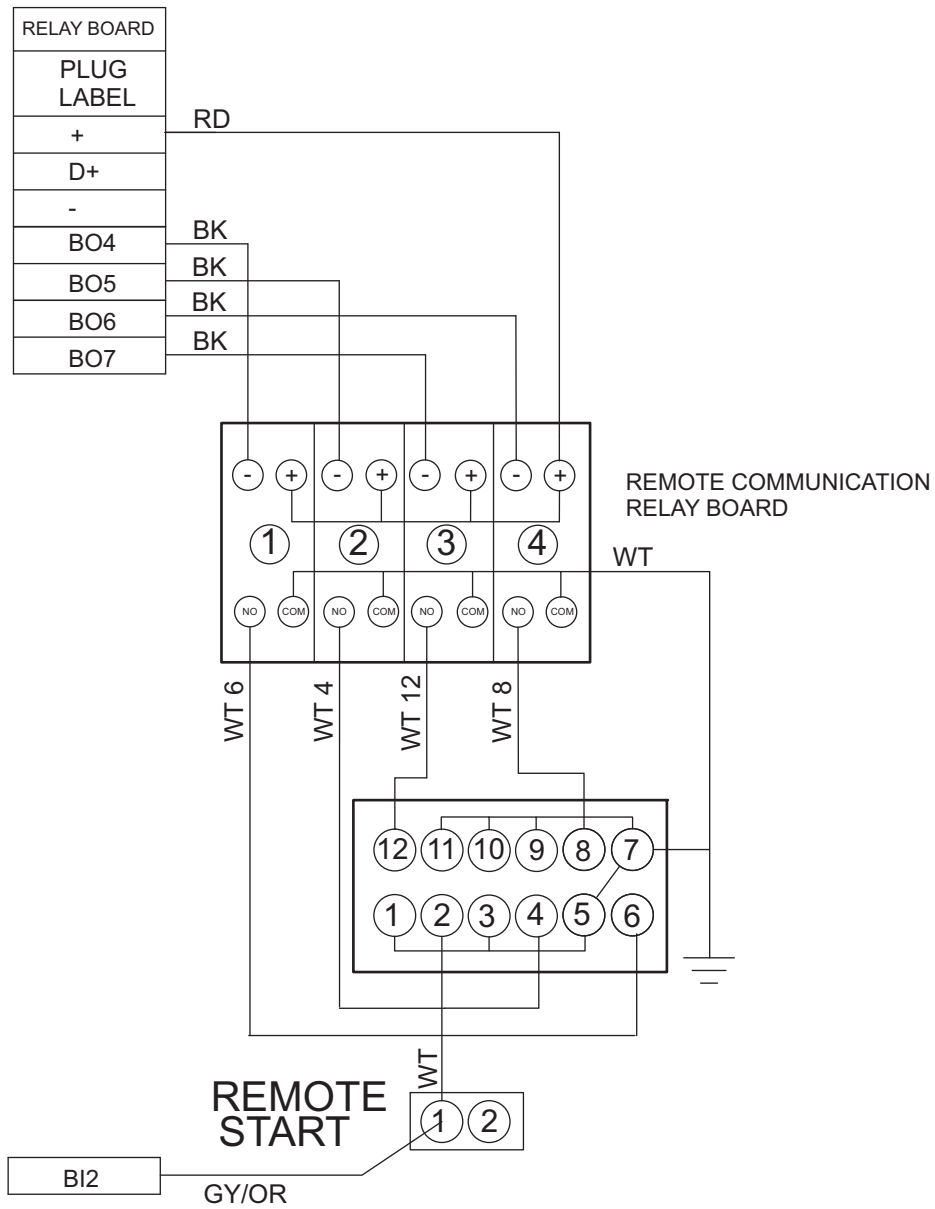

90416_P_07.27.16

Trailer Lights

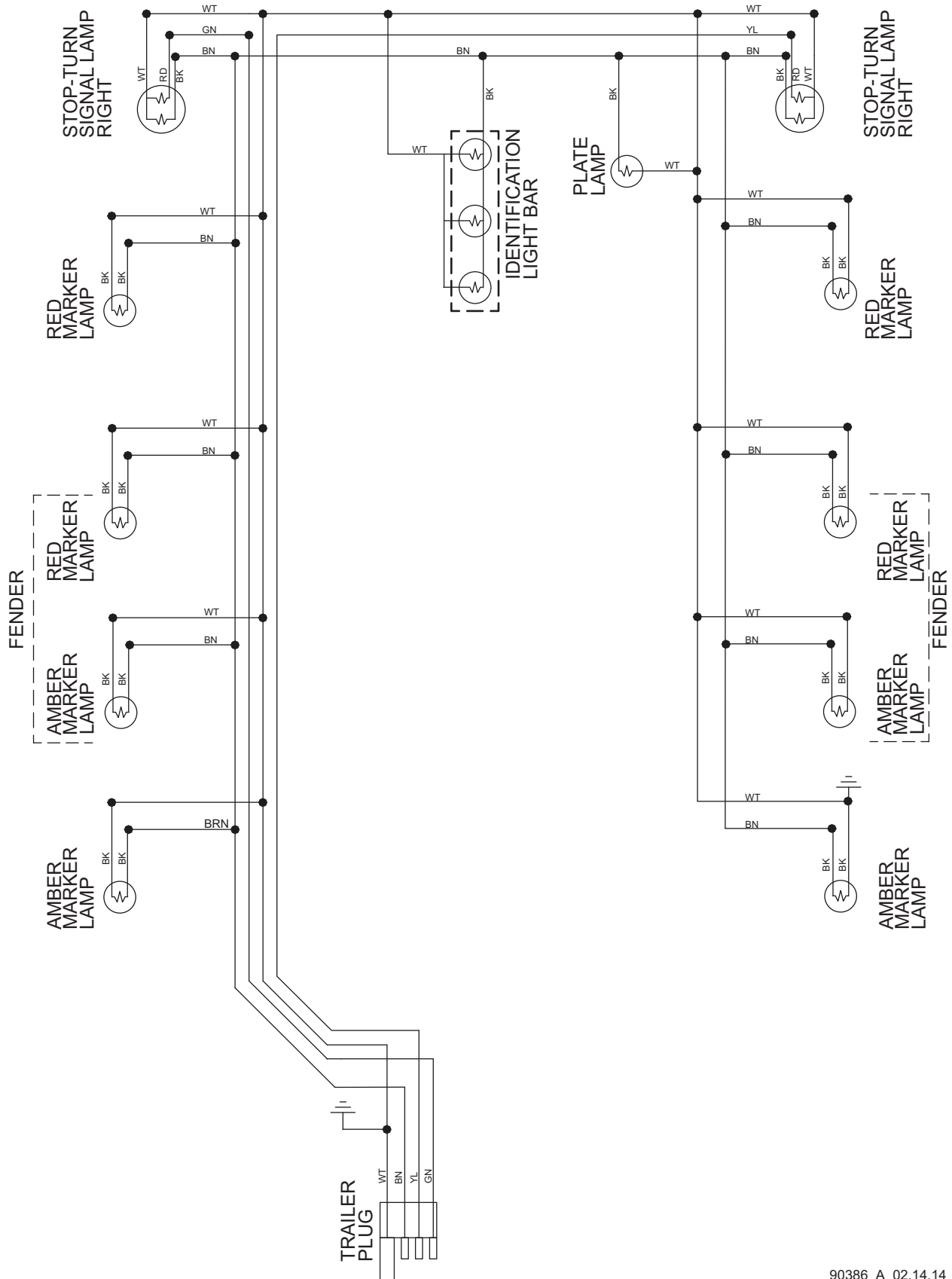

90386_A_02.14.14

Wiring Harness - Electric Brake

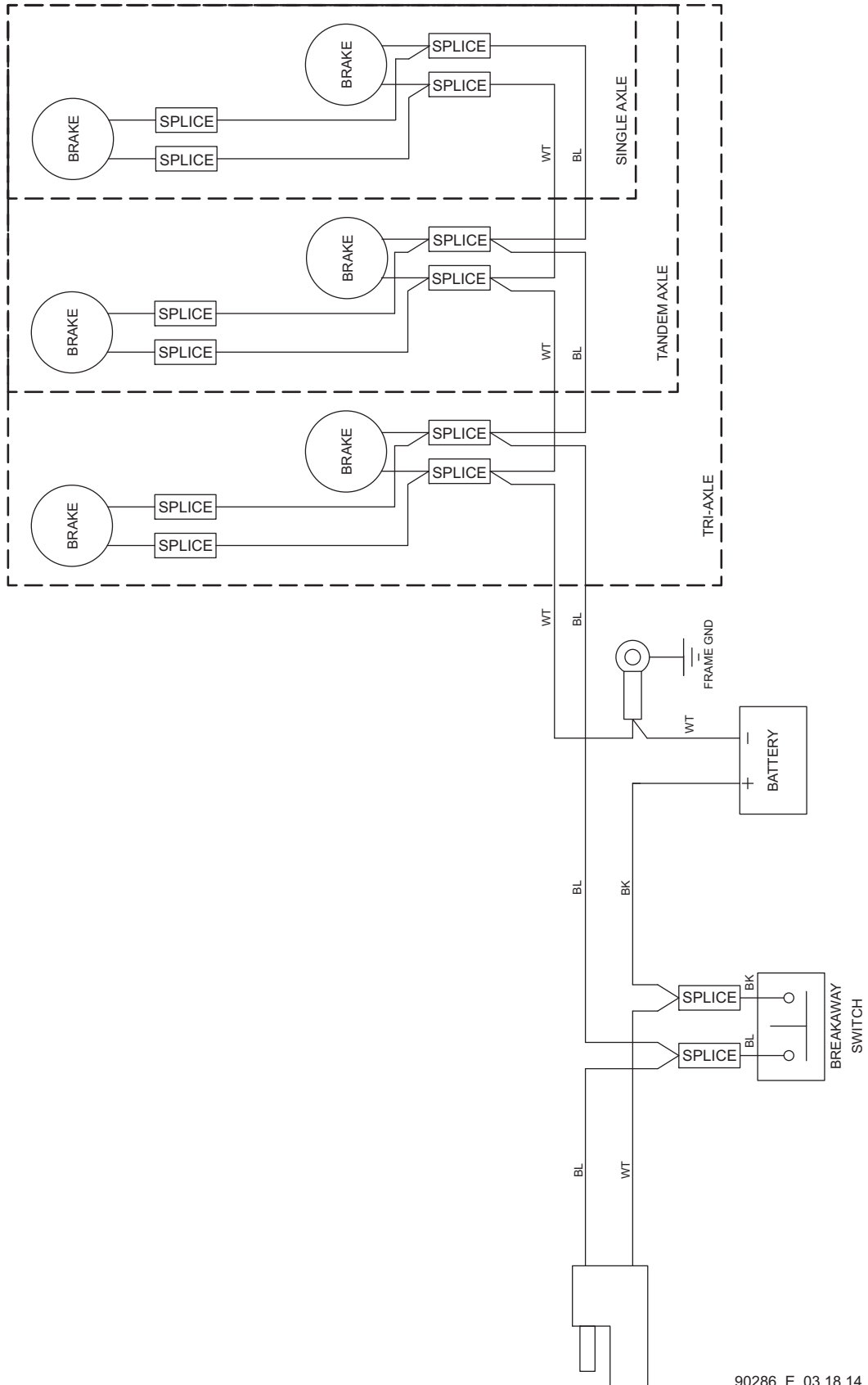

90286_E_03.18.14

Paralleling - Plug Resistor

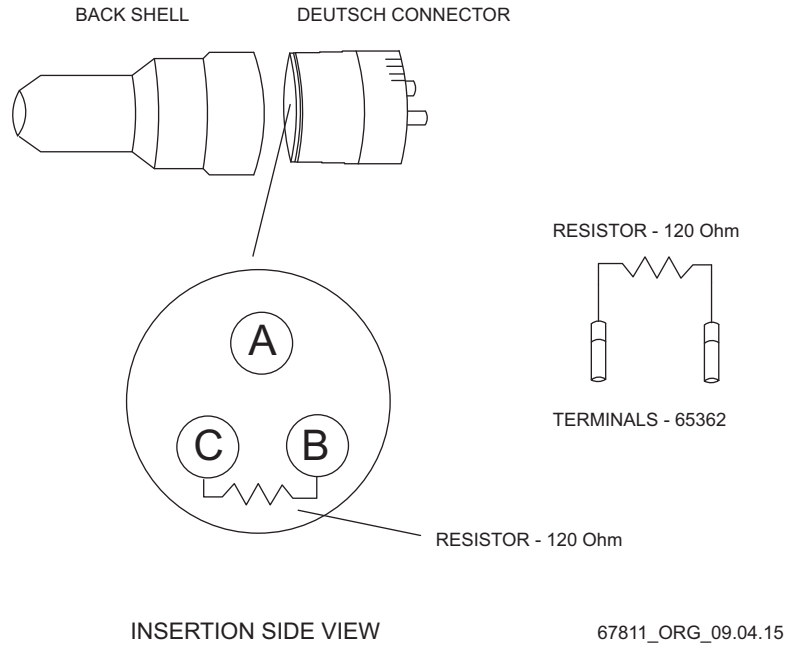

Paralleling - Cable Assembly

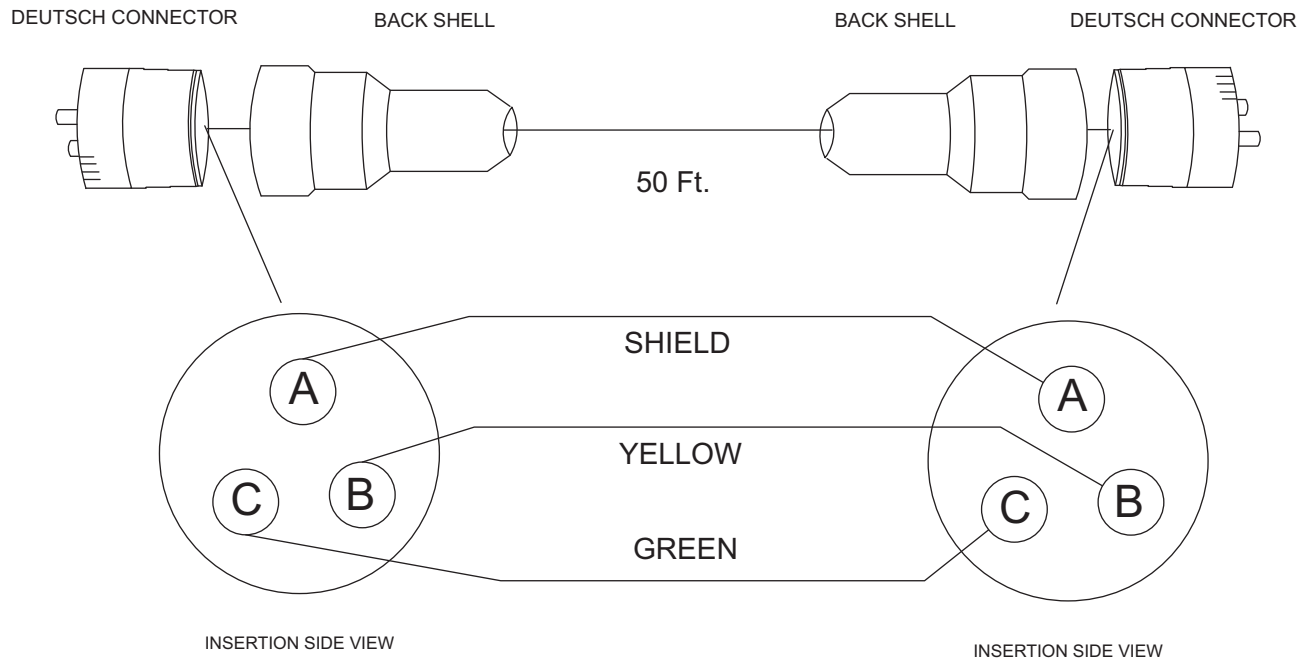

67812_ORG_09.03.15

Part No. 51197 Rev. A 10/31/16
©2016 Generac Mobile Products
All rights reserved.
Specifications are subject to change without notice.
No reproduction allowed in any form without prior written
consent from Generac Mobile Products.

GENERAC®

MAGNUM

Generac Mobile Products
215 Power Drive, Berlin, WI 54923
GeneracMobileProducts.com | 800-926-9768 | 920-361-4442